



Unlike any others ... that's cost & value for you

Professional UHF Wireless Microphone System

VM-82U G2



G2 SERIES

Generation 2

Operating Instructions



Frequency Selectable











2-in-1 Base Module**1 Receive Module with 2 Wireless Microphones System

Thank you for purchasing this unit. To make full and effective use of this unit, please read this Owner's Manual carefully before operating it. Please retain this manual for future reference.

Passionate about Music
www.BetterMusicBuilder.com

CONTENTS

	INTRODUCTION.....	3
	SYSTEM FEATURES.....	3
	PACKAGE ACCESSORIES.....	4
	2-in-1 BASE MODULE	
	Controls And Functions.....	5
	Hardware Setup.....	6~7
	Operation.....	8~9
	HANDHELD MICROPHONE	
	Controls And Functions.....	10~11
	Hardware Setup.....	12~13
	Operation.....	14
	TECHNICAL SPECIFICATION.....	15
	TROUBLESHOOTING.....	16~17
	APPENDIX.....	18~21
	WARRANTY.....	22



INTRODUCTION

The new VM-82U G2 wireless microphone is the second generation of UHF wireless microphone system designed by the engineering team of Better Music Builder.

VM-82U G2 is designed for both commercial and public use. It is a heavy duty design which includes two hand-held microphones with one 2-in-1 Base Module. Each hand-held microphone has a 32 selectable channels. The two microphones together have a total of 64 channels. By designs, the 32 channels frequencies can cover most of the worldwide allowable frequency bands. We have set up 32 channels for each microphone to make the frequency selection easily. The exceptional use of dual 2-in-1 Base Module in the 2-in-1 Base Module allows for the use of two channels to be on at one time improves signal quality and noise interference prevention. This system is reliable for use by KTV clubs, restaurants, coffee shops and churches, etc.



SYSTEM FEATURES

1. Equipped with the latest wireless technology and UHF dual-channel in one 2-in-1 Base Module to picks up weak signals and prevents signal interference.
2. Clear LCD screen that can allow you to check AF (Audio Frequency) and RF (Radio Frequency) signal and battery levels.
3. One 2-in-1 Base Module has two built-in receiver units (Receiver A and Receiver B).
4. Easy to select channels with pre-set frequencies.
5. Each microphone has 32 channels. There are a total of 64 channels in two microphones.
6. Easy and convenient mounting for portable rack.
7. Adjustable antennas for different angles for better receive signals sensitivity.



PACKAGE ACCESSORIES

The package comes with one 2-in-1 Base Module, two handheld microphone, one DC adaptor, one audio cable, four AA rechargeable batteries, and two antennas.

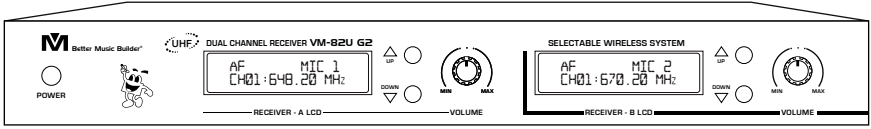

2-in-1 Base Module: 1 Set

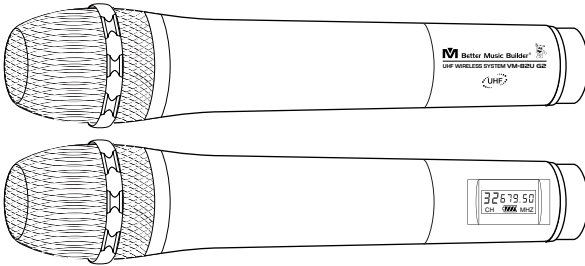

Hand-held Transmitter: Set of 2

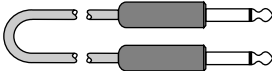

Audio Cable (for mixed out): 1 Unit



For better quality connections, a XLR to XLR cable is highly recommended.

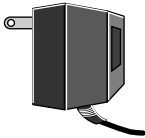

DC Power Adaptor: 1 Unit

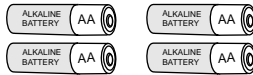

AA (1.5V) Battery: 4 Units

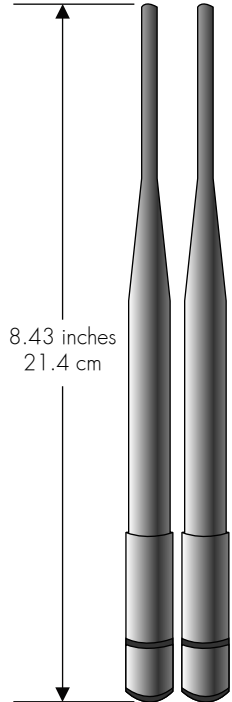

Receiving Antenna: 2 Units



2-in-1 BASE MODULE

CONTROLS AND FUNCTIONS

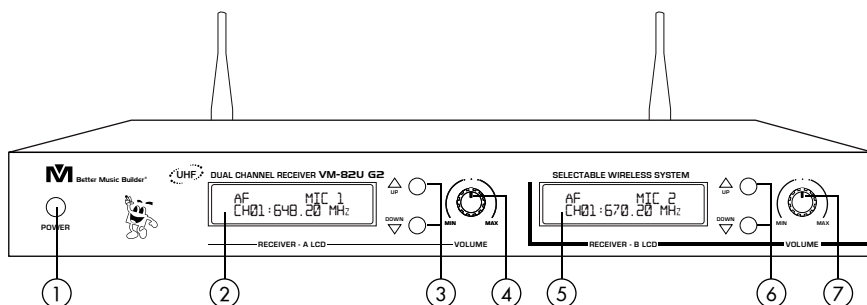

Front Panel:

1. Power button On/Off.
2. Receiver A LCD screen: Channel number with 32 Built-In Selectable UHF frequencies.
3. "▼" "▲" buttons scroll the different Channel numbers and frequencies in Receiver A to match the handheld microphone channel number and frequency.
4. Volume control for Receiver A
5. Receiver B LCD screen: Channel number with 32 Built-In Selectable UHF frequencies.
6. "▼" "▲" buttons scroll the different Channel numbers and frequencies in Receiver B to match the handheld microphone channel number and frequency.
7. Volume control for Receiver B

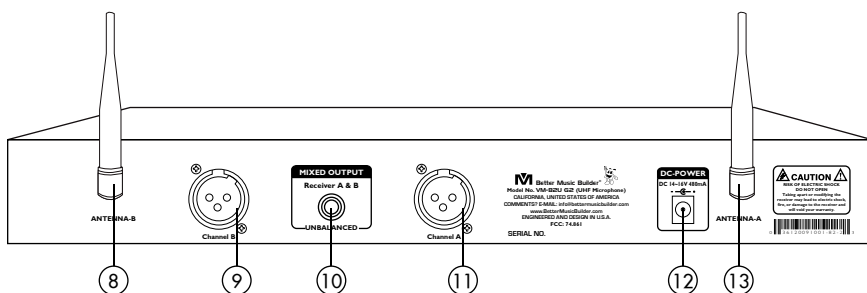

Rear Panel:

8. 2-in-1 Base Module Antenna Input-B. (Receiver B) BNC Socket.
9. Channel B XLR 3M socket balanced audio output 50Hz~15kHz +/-3dB.
10. Receiver A & B 1/4-inch (6.3 mm) jack socket unbalanced audio output, mixed channel A & B.
11. Channel A XLR balanced audio output 50Hz~15kHz +/-3dB.
12. Power supply dock with removable IEC cable 14~16V 480mA.
13. 2-in-1 Base Module Antenna Input-A. (Receiver A) BNC Socket.



HARDWARE SETUP

How to Connect Audio Out:

There are three different connectors as shown in the following diagram:

Connector 1 (Channel B) is a balanced XLR audio signal. If you connect B to the mixer or amplifier, then you can control the microphone effect on MIC B only.

Connector 2 is an unbalanced 1/4 audio signal. For Connector 2, both MIC A and MIC B will be mixed together to produce the same signal. To produce different effects on MIC A and MIC B, you need to connect them separately to the corresponding XLR Connector, Connector 1 to Channel B and Connector 3 to Channel A. Then you can adjust different echo or MIC tone effects on each microphone (i.e. MIC A and MIC B).

Connector 3 (Channel A) is a balanced XLR audio signal. If you connect A to the mixer or amplifier, then you can control the microphone effect on MIC A only.



We highly recommended using the XLR-balanced connections if distance between the 2-in-1 Base Module and mixer is more than 10 feet. The grounding of the XLR-balanced connection help reduces noise and delivers better quality signal.

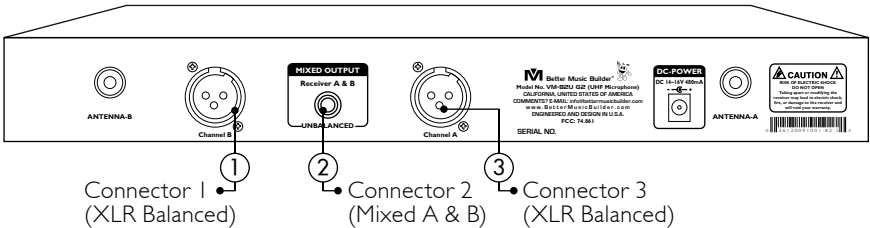

UHF Wireless System Diagram:

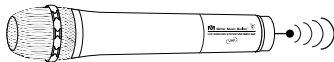

Channel A Handheld Microphone

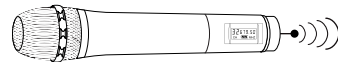

Channel B Handheld Microphone

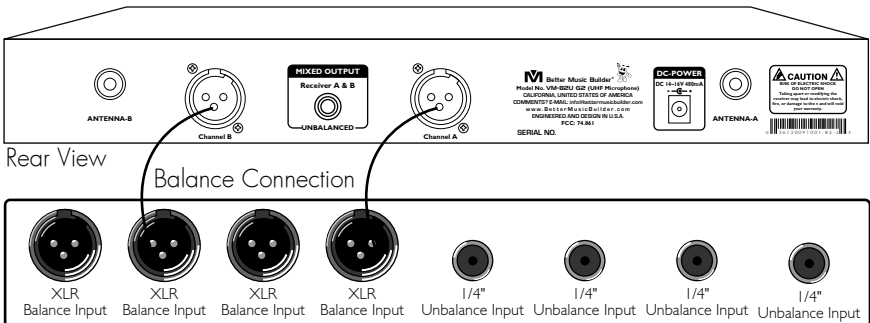

Audio Mixer Amplifier or a Karaoke Unit Input terminal

How to Connect the Antenna:

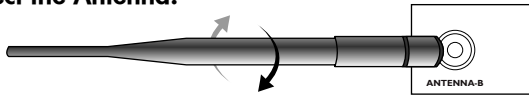

Screw the two antennas (BNC socket) into the rear panel of the 2-in-1 Base Module in a vertical 90° angle and turn it in clockwise to lock it.

How to Connect DC-Power:

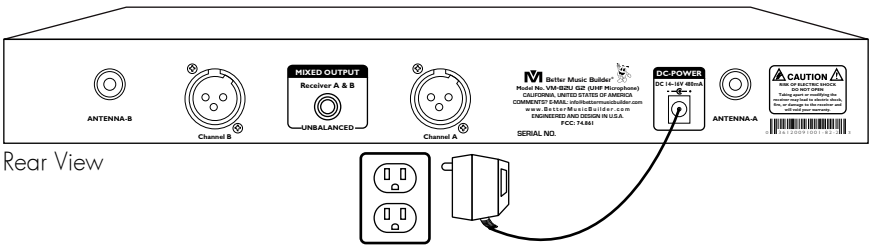

Rear View

For North America Market, use 120V, DC-14~16V 480mA adaptor. For market outside North America, use 220V~ 240V DC adaptor with a maximum battery capacity of 480mA.

NOTE ▶ Please make sure to use the right DC adaptor. Otherwise, it may damage the 2-in-1 Base Module and the charger because their maximum battery capacity is different. The product warranty will be void if you use the wrong DC adaptor.

Optional 19" Rack Mount Kit:

If you want to put the system onto a mount-kit, please follow the diagram below. Our special design feature allow it to be removable or mountable on a DJ rack.

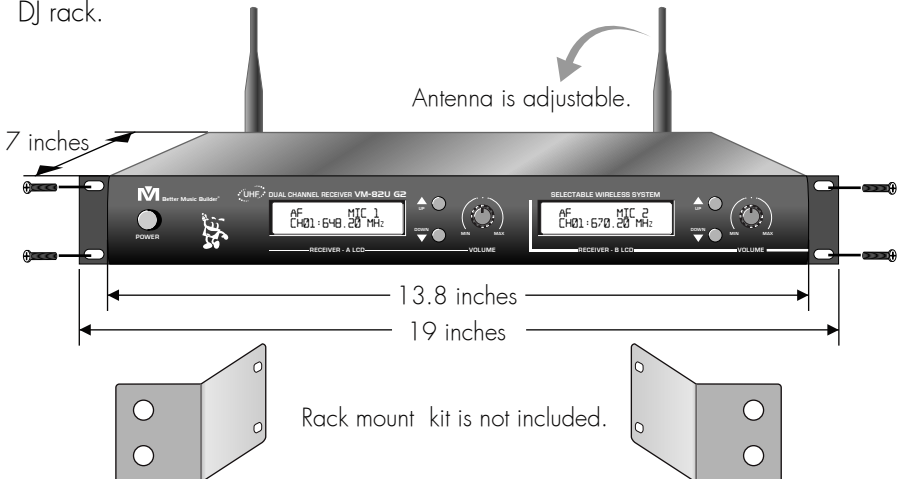

OPERATION

LCD Panel and Settings:

After turning on the "POWER" button, LCD screen will light up as below:

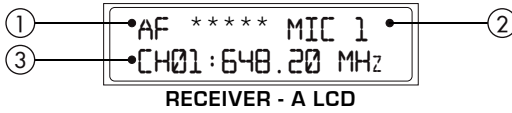

1. AF (audio frequency) Signal Indicator. "*****" indicates audio reception.
2. MIC Connection Indicator (RF - radio frequency signal). "MIC 1" for Receiver A or "MIC 2" for Receiver B, will be displayed only when the handheld microphone and 2-in-1 Base Module are synchronized, meaning the channel number and frequency are matched.
3. Current Channel/Frequency Display: current value depends on your setting.

NOTE ➤ If there is static or no sound coming out of your speakers, than there may be a frequency interruption from another system, change your frequency to match your handheld microphone's frequency.

How to Select Frequencies:

The 2-in-1 Base Module has two built-in receivers (Receiver A and B). The manufacturer has already pre-set a set of particular frequencies for each receiver. To select the desire frequency, you can use either Receiver A or B and press the up/down button to scroll for the available frequencies. Select the best frequency at either Receiver A or B. Both receivers can have the same channel number but different frequency since each channel were pre-assigned with unique frequency for each receiver.

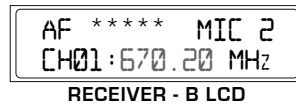
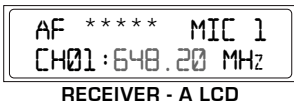

Pairing your microphone to the Receiver:

When you want to set up a particular frequency at Receiver A, you can scroll through the channels until a "MIC 1" (radio frequency) signal is displayed on the MIC Connection Indicator or "MIC 2" for Receiver B, which means that the handheld microphone and receiver are paired and can be used.

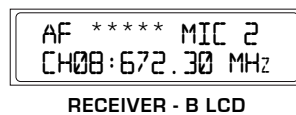
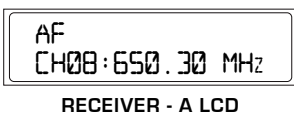

How To Adjust Receiver Settings:

To adjust your receiver's channel/frequency by pressing the "▲" UP or "▼" DOWN button to select your frequency.

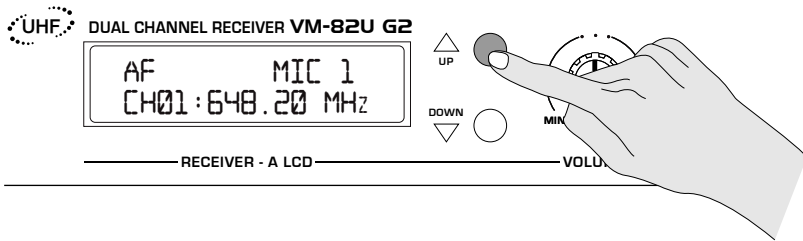

Each unit is fully tested and qualified by the manufacturer. However, due to the nature of wireless connection, strong interference from local environment and the huge amount of wireless devices within the household, it is possible that cross talk and interferences might occur.

If for some reason, the Receiver A or B is actively picking up AF signal and/or the RF Connection Indicator displayed "B" while the handheld microphone is not turn on yet. Then, this is an indication that a strong interference or the frequency channel is being used by some other active device within 200 feet radius. Hence, selecting different frequency channel is highly recommended by scrolling through the available channel with the up/down button on each receiver.

Turn "VOLUME" button to adjust your vocal volume.

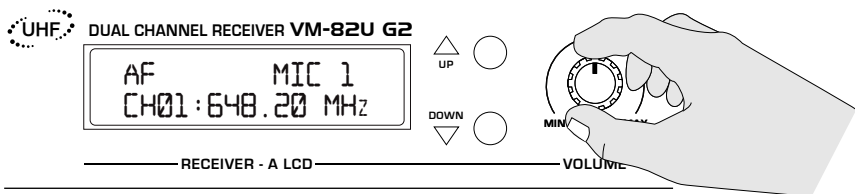

 We recommend setting the microphone volume to the center position, then control overall volume from the mixer.

NOTE ▶ If you or anyone do any damage on any part of the receiver either accidently or intentionally, we have the right to void your warranty.



HANDHELD MICROPHONE

CONTROLS AND FUNCTIONS

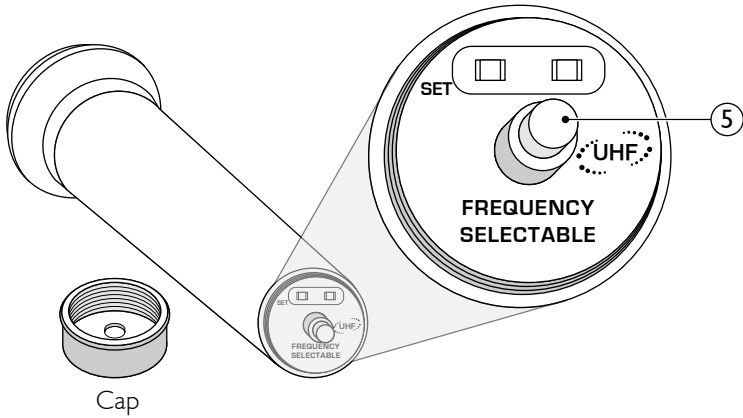
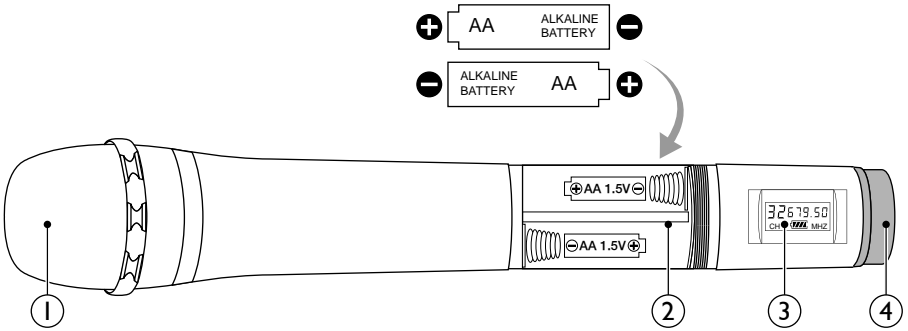

1. Interchangeable microphone head.
2. Battery Slots: insert 2x1.5V AA battery or 2x1.2V rechargeable battery.
3. LCD Digital Display.
4. Bottom Cap.
5. Power Button: Press and hold the handheld for 3 seconds to turn power ON/OFF.

LCD Panel:

After turning on the "POWER", the LCD screen will light up as below:

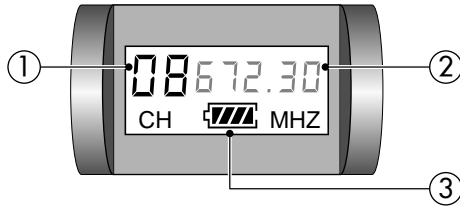

1. Channel Number: Current value depends on your setting.
2. Frequency: Current value depends on your setting.
3. Battery Status: Indicates charge remaining in microphone batteries.

Battery Status:

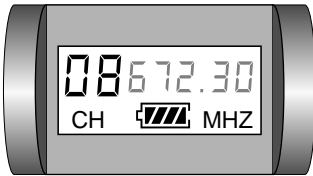

Full Battery

Indicates a full battery on the microphone. The engineering team of Better Music Builder uses the latest technology to indicate the battery status, so you can see the battery strength.

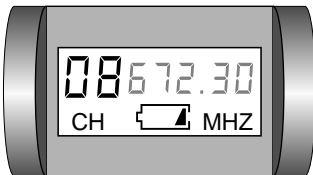

Low Battery

Indicates a low battery on the microphone. When it shows a low battery as shown on the left, you need to change the battery immediately.



Battery icon will blink constantly when battery is extremely low and about to die.

NOTE

After pressing the power button for three seconds, the microphone should turn on. If the microphone is still off, please check the battery. It may very low. Please change your battery immediately. Typical new full battery life should have a 4-6 hours battery life with our system, otherwise, the battery might be defective or near expired. The battery is not covered under our product warranty.



HARDWARE SETUP

How to Insert Batteries:

1. Twist open battery cover.

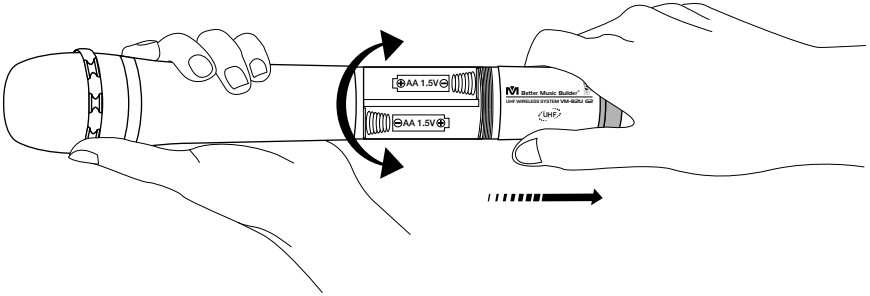

2. Use one hand to hold onto the top of your Microphone, with your other hand slide 2 AA batteries into battery slot. Be careful not to drop Microphone while inserting batteries.

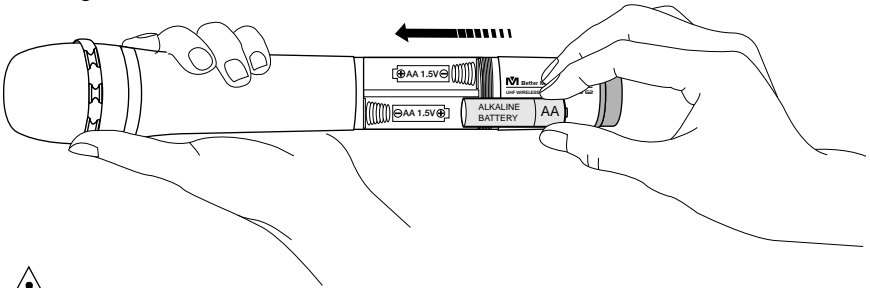

 Make sure to follow the polarity of the battery according to the battery slots.

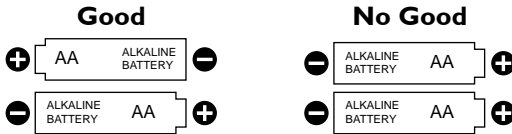

3. Twist back battery cover.

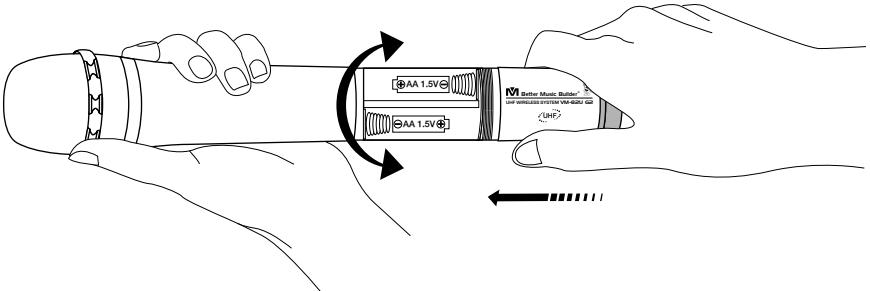

How to Turn On And Off Hand-held Microphone:

Press and hold power button to turn on/off your microphone. When "ON", microphone's LCD screen will displays Channel Number, Frequency, and Battery Status. When "OFF", microphone's LCD screen will be off.

NOTE

After pressing the button for three seconds, the transmitter should turn on. If the transmitter is still off, please check the battery. It may very low. You need to change the battery or recharge it immediately.

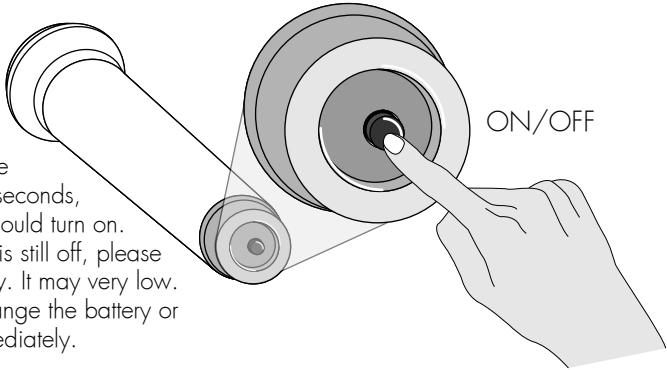

How to Interchange Microphone Head:

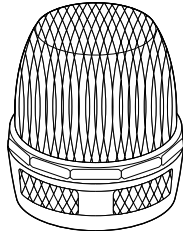
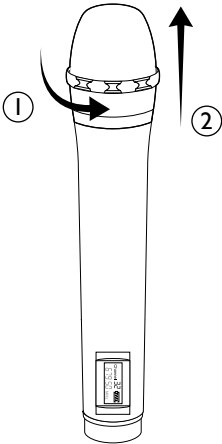

Interchangeable microphone head

NOTE

You can order the replacement parts (such as the microphone head as shown in the above figure) from any of our authorized dealers.

Switch The Caps With 6 Different Colors:



Green



Blue



Yellow



Silver



Orange



Black

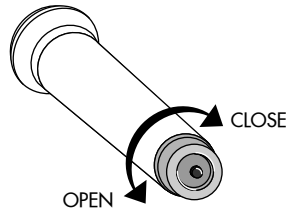

(*Optional: You can switch the caps with 6 different colors; green, blue, yellow, silver, orange and black. Sold separately)

OPERATION

How to Change the Handheld Microphone Default Frequency Channel:

First, twist to release the bottom cap.

Second, to change the settings. After Power Up, press the SET button right away to switch to the Adjust Mode and scroll "UP" or "DOWN" (the button next to SET button) to select the desire Channel Number.

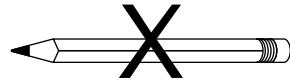
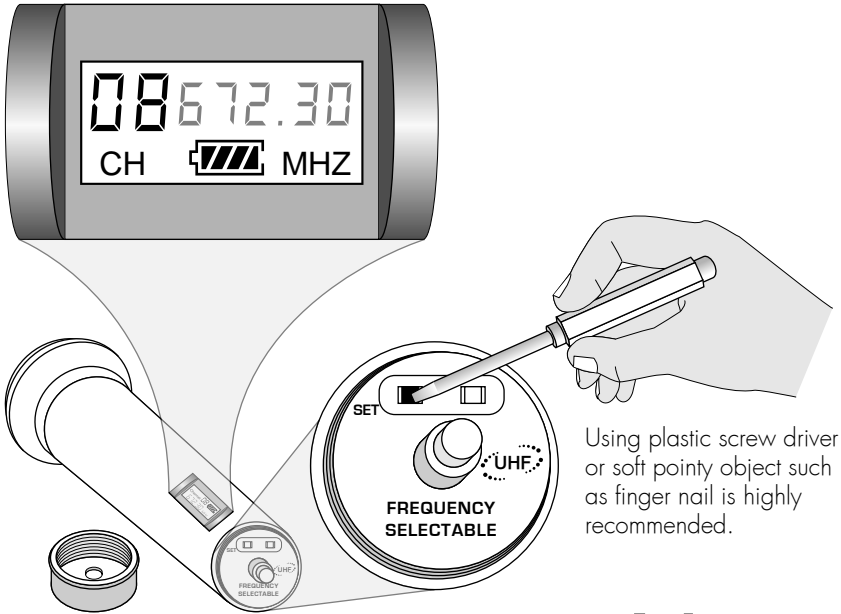

Do not use pencil and metal screw driver



1. Match your frequency on the microphone to that on the 2-in-1 Base Module for a better signal.
2. Damage because of improper usage will void your warranty.
3. Do not use metal screw driver or the likes for adjustments. It may damage the transmitter and void your warranty.



TECHNICAL SPECIFICATION

A. TECHNOLOGICAL FEATURE OF THE 2-in-1 BASE MODULE:

1. Frequency Range: UHF 550.20~690.80MHz
2. Signal to Noise Ratio: > 90dB
3. Total Harmonic Distortion: < 0.02%
4. Frequency Stability: < ± 30 ppm
5. Frequency Response: 40Hz ~ 15kHz ± 3 dB
6. Dynamic Range: >90dB
7. Image & Spurious Rejection: >80dB
8. Channel Rejection: >80dB
9. Receiver Sensitivity: <30dB (10dBu)
10. De-Emphasis: 50us
11. Audio Output Level: Unbalanced Out: 0-- ± 400 mV
Balanced Out: 0-- ± 200 mV
12. Power Supply: AC 110V (For 220V, you may need to change to a 220V~240V DC adaptor)
13. Consume Power: 5 Watt
13. Receiver Dimensions (WxHxD): 13.8x1.8x7.2 (inches)/35x4.5x18.3 (cm)
14. Shipping Weight: 7.2 lbs / 3.3 kg

B. TECHNOLOGICAL FEATURE OF THE MICROPHONE:

1. Transmitter Power: 8.5mW
2. Modulation Type: FM, F3F
3. Max Deviation: ± 25 kHz
4. Spurious Emission: >40dB (With Carrier)
5. Battery Voltage: 2 - AA 1.5V Battery
6. Continuous Using: 6 Hours (GP) 1604s 2 - AA 1.5V Battery
7. Microphone Dimensions (WxH): 1.96 x 9.3 (inches) / 5 x 23.7 (cm)

THIS SYSTEM INCLUDES THE FOLLOWING

2-in-1 Base Module: 1 Set
Handheld Microphone: 2 Sets
AA 1.5V Battery: 4 Units
Antenna: 2 Units
DC-Power adaptor: 1 Unit
Audio Connecting Cable: 1 Unit
Instructional Manual: 1 pcs



TROUBLESHOOTING

1. SYMPTOM: 2-in-1 Base Module HAS NO POWER OR CONSTANTLY FLASHING.

If you press the power button on the 2-in-1 Base Module for more than 5 seconds and the 2-in-1 Base Module screen is flashing or doesn't turn light up, you may be using the wrong DC adaptor or the DC voltage is not correct. There are two types of adaptor; AC adaptor and DC adaptor. The 2-in-1 Base Module uses 1.5V-DC 600mA adapter.

2. SYMPTOM: NO SOUND

Before there was sound coming from the speaker, but now there is no sound. Please double check your cable connection to the receiver system. It could also be the microphone 2-in-1 Base Module frequency and the hand-held microphone frequency is not matched. Please refer to page 8 of manual for details. Or it could be the battery problem on the microphone.

When you change a new battery, but there is still no sound, the battery may be placed in a wrong position inside the microphone. Once, the battery are install properly and there is still no sound. Check to see if the 2-in-1 Base Module LCD panel displayed "MIC 1" or "MIC 2". If there is, then it could be the microphone head (part# KOM82U324) is damaged and need to be repaired (contact manufacturer for technical support).

3. SYMPTOM: NOISE AND INTERFERENCE

If you connect the 2-in-1 Base Module audio out to the mixer for more than 10 feet, we recommend you changing it to a balanced cable (XLR to XLR). It would reduce the noises due to the higher grade grounding of the cable.

If you hear some random noises from your speaker, but the microphone is off, it means that the current frequency channel is being used by some other wireless device within 200 feet. Or the sensitivity of the 2-in-1 Base Module is picking up some random noise from the surrounding area. Therefore, we recommend changing to a different available frequency channel.

When the handheld microphone is off, but if the "MIC 1" or "MIC 2" radio frequency is on. This is an indication that the frequency channel is not clean and might already been occupied. A different channel frequency **MUST** be selected. Both the handheld microphone and the 2-in-1 Base Module must change to a matching frequency. Please refer to the manual page 14 for how to change the frequency channel on the handheld microphone, and page 8 for details on how to select the frequency channel on your 2-in-1 Base Module.

4. SYMPTOM: POOR SIGNAL

When the 2-in-1 Base Module and handheld microphone are placed in different rooms made of concrete wall. This would cause poor signal.

Your audio equipment is close to the police, fire or radio stations. In this case, a different channel frequency **MUST** be selected. Both the handheld microphone and the 2-in-1 Base Module must change to a matching frequency. Please refer to the manual page 14 for how to change the frequency channel on the handheld microphone, and page 8 for details on how to select the frequency channel on your 2-in-1 Base Module.

5. SYMPTOM: THE FREQUENCY OF THE HANDHELD MICROPHONE IS DIFFERENT FROM THAT OF THE 2-in-1 Base Module.

The microphone A must match with 2-in-1 Base Module A. If the microphone A matches with 2-in-1 Base Module B, it would have different frequency. Please refer to "How to Change the Hand-held Microphone Default Frequency Channel" on page 14.

6. SYMPTOM: THE SPEAKER MADE RANDOM NOISES.

It is also possible that the audio cable has poor quality. Therefore, you may need to use another cable of higher quality.

The basic 1/4 jack cable provide audio signal from the 2-in-1 Base Module to the mixing amplifier with in 6 feet. If more than that, the higher grade cable XLR to XLR balanced with more grounding **MUST** be used.

7. SYMPTOM: HANDHELD MICROPHONE CANNOT BE TURNED ON.

When you push the power button of the handheld microphone for more than 3 seconds, the microphone should turn ON. There are several possibilities that it wouldn't:

- You may place the batteries at the wrong polarity.
- The batteries are very low or dead.

Therefore, you need to change to new batteries and make sure that the batteries are fully charged. If the new fully charged battery life is used. It should last hours. Otherwise, it is very possible that the batteries are defective when purchase. It is not the problem from the handheld microphone(s).



APPENDIX

VM-82U G2 FCC FREQUENCY 550 MHz and 690 MHz

UHF Frequencies Available for Use for Home Electronics in North America

The RF radio frequencies used in the transmission of wireless information are closely regulated in most countries including North America. A lot of countries strictly enforce their regulations stating which RF frequencies are available for use for certain device, so it can help limit the amount of radio frequency interference in all wireless communications.

Please refer to the following two tables for Group A and Group B with available RF frequencies. If the RF frequencies indicated in the following two tables for Group A and Group B are in conflicts with the local wireless information law in your country, you may change to a different product model or contact our technicians for advice.

FCC Information to User for Reference

This equipment is designed in compliance with the limits for a Class A digital device pursuant to part 15 of the FCC Rules from the United States of America. These limits are designed to provide protection against harmful interference when the equipment is operated in public environment. This equipment generates, uses, and can radiate radio frequency energy and, if not installed and used in accordance with the instruction manual, may cause harmful interference to radio communications. Operation of this equipment in a residential area is likely to cause harmful interference, so that the user will be required to correct the interference at his own expense.

Group A

Channel Number	Receiver A Mic 1 Frequency	Receiver B Mic 2 Frequency
1	648.20 MHz	670.20 MHz
2	648.50 MHz	670.50 MHz
3	648.80 MHz	670.80 MHz
4	649.10 MHz	671.10 MHz
5	649.40 MHz	671.40 MHz
6	649.70 MHz	671.70 MHz
7	650.00 MHz	672.00 MHz
8	650.30 MHz	672.30 MHz
9	650.60 MHz	672.60 MHz
10	650.90 MHz	672.90 MHz
11	651.20 MHz	673.20 MHz
12	651.50 MHz	673.50 MHz
13	651.80 MHz	673.80 MHz
14	652.10 MHz	674.10 MHz
15	652.40 MHz	674.40 MHz
16	652.70 MHz	674.70 MHz
17	653.00 MHz	675.00 MHz
18	653.30 MHz	675.30 MHz
19	653.60 MHz	675.60 MHz
20	653.90 MHz	675.90 MHz
21	654.20 MHz	676.20 MHz
22	654.50 MHz	676.50 MHz
23	654.80 MHz	676.80 MHz
24	655.10 MHz	677.10 MHz
25	655.40 MHz	677.40 MHz
26	655.70 MHz	677.70 MHz
27	656.00 MHz	678.00 MHz
28	656.30 MHz	678.30 MHz
29	656.60 MHz	678.60 MHz
30	656.90 MHz	678.90 MHz
31	657.20 MHz	679.20 MHz
32	657.50 MHz	679.50 MHz

Group B

Channel Number	Receiver A Mic 1 Frequency	Receiver B Mic 2 Frequency
1	763.20 MHz	787.20 MHz
2	763.50 MHz	787.50 MHz
3	763.80 MHz	787.80 MHz
4	764.10 MHz	788.10 MHz
5	764.40 MHz	788.40 MHz
6	764.70 MHz	788.70 MHz
7	765.00 MHz	789.00 MHz
8	765.30 MHz	789.30 MHz
9	765.60 MHz	789.60 MHz
10	765.90 MHz	789.90 MHz
11	766.20 MHz	790.20 MHz
12	766.50 MHz	790.50 MHz
13	766.80 MHz	790.80 MHz
14	767.10 MHz	791.10 MHz
15	767.40 MHz	791.40 MHz
16	767.70 MHz	791.70 MHz
17	768.00 MHz	792.00 MHz
18	768.30 MHz	792.30 MHz
19	768.60 MHz	792.60 MHz
20	768.90 MHz	792.90 MHz
21	769.20 MHz	793.20 MHz
22	769.50 MHz	793.50 MHz
23	769.80 MHz	793.80 MHz
24	770.10 MHz	794.10 MHz
25	770.40 MHz	794.40 MHz
26	770.70 MHz	794.70 MHz
27	771.00 MHz	795.00 MHz
28	771.30 MHz	795.30 MHz
29	771.60 MHz	795.60 MHz
30	771.90 MHz	795.90 MHz
31	772.20 MHz	796.20 MHz
32	772.50 MHz	796.50 MHz

FREQUENCY SCAN GROUPS FOR GROUP-C & GROUP-D

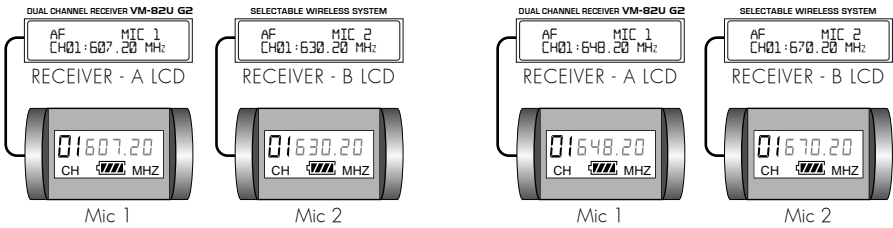

Group C

Channel Number	Receiver A Mic 1 Frequency	Receiver B Mic 2 Frequency
1	607.20 MHz	630.20 MHz
2	607.50 MHz	630.50 MHz
3	607.80 MHz	630.80 MHz
4	601.10 MHz	631.10 MHz
5	601.40 MHz	631.40 MHz
6	601.70 MHz	631.70 MHz
7	602.00 MHz	632.00 MHz
8	602.30 MHz	632.30 MHz
9	602.60 MHz	632.60 MHz
10	602.90 MHz	632.90 MHz
11	603.20 MHz	633.20 MHz
12	603.50 MHz	633.50 MHz
13	603.80 MHz	633.80 MHz
14	604.10 MHz	634.10 MHz
15	604.40 MHz	634.40 MHz
16	604.70 MHz	634.70 MHz
17	605.00 MHz	635.00 MHz
18	605.30 MHz	635.30 MHz
19	605.60 MHz	635.60 MHz
20	605.90 MHz	635.90 MHz
21	606.20 MHz	636.20 MHz
22	606.50 MHz	636.50 MHz
23	606.80 MHz	636.80 MHz
24	607.10 MHz	637.10 MHz
25	607.40 MHz	637.40 MHz
26	607.70 MHz	637.70 MHz
27	608.00 MHz	638.00 MHz
28	608.30 MHz	638.30 MHz
29	608.60 MHz	638.60 MHz
30	608.90 MHz	638.90 MHz
31	616.20 MHz	639.20 MHz
32	616.50 MHz	639.50 MHz

Group D

Channel Number	Receiver A Mic 1 Frequency	Receiver B Mic 2 Frequency
1	648.20 MHz	670.20 MHz
2	648.50 MHz	670.50 MHz
3	648.80 MHz	670.80 MHz
4	649.10 MHz	671.10 MHz
5	649.40 MHz	671.40 MHz
6	649.70 MHz	671.70 MHz
7	650.00 MHz	672.00 MHz
8	650.30 MHz	672.30 MHz
9	650.60 MHz	672.60 MHz
10	650.90 MHz	672.90 MHz
11	651.20 MHz	673.20 MHz
12	651.50 MHz	673.50 MHz
13	651.80 MHz	673.80 MHz
14	652.10 MHz	674.10 MHz
15	652.40 MHz	674.40 MHz
16	652.70 MHz	674.70 MHz
17	653.00 MHz	675.00 MHz
18	653.30 MHz	675.30 MHz
19	653.60 MHz	675.60 MHz
20	653.90 MHz	675.90 MHz
21	654.20 MHz	676.20 MHz
22	654.50 MHz	676.50 MHz
23	654.80 MHz	676.80 MHz
24	655.10 MHz	677.10 MHz
25	655.40 MHz	677.40 MHz
26	655.70 MHz	677.70 MHz
27	656.00 MHz	678.00 MHz
28	656.30 MHz	678.30 MHz
29	656.60 MHz	678.60 MHz
30	656.90 MHz	678.90 MHz
31	657.20 MHz	679.20 MHz
32	657.50 MHz	679.50 MHz

US UHF WIRELESS OPERATING FREQUENCIES

TV ch.	Band C: 541.500 - 566.375 MHz							
25	–	–	–	–	541.500	541.625	541.750	541.875
26	542.000	542.125	542.250	542.375	542.500	542.625	542.750	542.875
26	543.000	543.125	543.250	543.375	543.500	543.625	543.750	543.875
26	544.000	544.125	544.250	544.375	544.500	544.625	544.750	544.875
26	545.000	545.125	545.250	545.375	545.500	545.625	545.750	545.875
26	546.000	546.125	546.250	546.375	546.500	546.625	546.750	546.875
26	547.000	547.125	547.250	547.375	547.500	547.625	547.750	547.875
27	548.000	548.125	548.250	548.375	548.500	548.625	548.750	548.875
27	549.000	549.125	549.250	549.375	549.500	549.625	549.750	549.875
27	550.000	550.125	550.250	550.375	550.500	550.625	550.750	550.875
27	551.000	551.125	551.250	551.375	551.500	551.625	551.750	551.875
27	552.000	552.125	552.250	552.375	552.500	552.625	552.750	552.875
27	553.000	553.125	553.250	553.375	553.500	553.625	553.750	553.875
28	554.000	554.125	554.250	554.375	554.500	554.625	554.750	554.875
28	555.000	555.125	555.250	555.375	555.500	555.625	555.750	555.875
28	556.000	556.125	556.250	556.375	556.500	556.625	556.750	556.875
28	557.000	557.125	557.250	557.375	557.500	557.625	557.750	557.875
28	558.000	558.125	558.250	558.375	558.500	558.625	558.750	558.875
28	559.000	559.125	559.250	559.375	559.500	559.625	559.750	559.875
29	560.000	560.125	560.250	560.375	560.500	560.625	560.750	560.875
29	561.000	561.125	561.250	561.375	561.500	561.625	561.750	561.875
29	562.000	562.125	562.250	562.375	562.500	562.625	562.750	562.875
29	563.000	563.125	563.250	563.375	563.500	563.625	563.750	563.875
29	564.000	564.125	564.250	564.375	564.500	564.625	564.750	564.875
29	565.000	565.125	565.250	565.375	565.500	565.625	565.750	565.875
30	566.000	566.125	566.250	566.375	–	–	–	–

Avoid using same frequencies as TV channels or other radio signals for better performance.

TV ch.	Band D: 655.500 - 680.375 MHz							
44	–	–	–	–	655.500	655.625	655.750	655.875
45	656.000	656.125	656.250	656.375	656.500	656.625	656.750	656.875
45	657.000	657.125	657.250	657.375	657.500	657.625	657.750	657.875
45	658.000	658.125	658.250	658.375	658.500	658.625	658.750	658.875
45	659.000	659.125	659.250	659.375	659.500	659.625	659.750	659.875
45	660.000	660.125	660.250	660.375	660.500	660.625	660.750	660.875
45	661.000	661.125	661.250	661.375	661.500	661.625	661.750	661.875
46	662.000	662.125	662.250	662.375	662.500	662.625	662.750	662.875
46	663.000	663.125	663.250	663.375	663.500	663.625	663.750	663.875
46	664.000	664.125	664.250	664.375	664.500	664.625	664.750	664.875
46	665.000	665.125	665.250	665.375	665.500	665.625	665.750	665.875
46	666.000	666.125	666.250	666.375	666.500	666.625	666.750	666.875
46	667.000	667.125	667.250	667.375	667.500	667.625	667.750	667.875
47	668.000	668.125	668.250	668.375	668.500	668.625	668.750	668.875
47	669.000	669.125	669.250	669.375	669.500	669.625	669.750	669.875
47	670.000	670.125	670.250	670.375	670.500	670.625	670.750	670.875
47	671.000	671.125	671.250	671.375	671.500	671.625	671.750	671.875
47	672.000	672.125	672.250	672.375	672.500	672.625	672.750	672.875
47	673.000	673.125	673.250	673.375	673.500	673.625	673.750	673.875
48	674.000	674.125	674.250	674.375	674.500	674.625	674.750	674.875
48	675.000	675.125	675.250	675.375	675.500	675.625	675.750	675.875
48	676.000	676.125	676.250	676.375	676.500	676.625	676.750	676.875
48	677.000	677.125	677.250	677.375	677.500	677.625	677.750	677.875
48	678.000	678.125	678.250	678.375	678.500	678.625	678.750	678.875
48	679.000	679.125	679.250	679.375	679.500	679.625	679.750	679.875
49	680.000	680.125	680.250	680.375	–	–	–	–

Avoid using same frequencies as TV channels or other radio signals for better performance.



WARRANTY

One-Year Limited Warranty for Home Use Equipment

Our one-year warranty applies to speakers, amplifiers, mixers and microphones for home use only. It covers both parts and labors. The warranty becomes effective from the date of your purchase for one year.

Our warranty only covers defects due to product defectiveness with free of defects in materials or workmanship. However, our warranty does not cover defects due to normal wears, damage in transit, improper use, abuse or failure to follow the proper instructions for maintenance. This warranty is void in the event of unauthorized repairs, alternations, modifications and removing of the product label.

Please also note that our warranty does not cover any shipping cost for the return of defective products to us for inspection, repair and maintenance. Our warranty for Better Music Builder products can only be executed in North America.

NOTE ➤ Our warranty does not cover the battery for wireless microphone products.

90-Day Limited Warranty for Public and Commercial Use Equipment

Our 90-day warranty applies to speakers, amplifiers, mixers and microphones for both public and commercial use such as restaurant, coffee shop, KTV nightclub, church and school, etc. It covers both parts and labors. The warranty becomes effective from the date of your purchase for 90 days.

To Register Your Warranty

Please fill out the warranty card that came with your unit, download or submit online warranty form. However, we need the invoice for your purchase in order to process this warranty. You may also register your warranty online.

Please visit our website at www.bettermusicbuilder.com.

PRECAUTION

1. If you want to use more than one of this system, please select the operating frequency or signal channel carefully so as to avoid disturbing.
2. The input power voltage of the 2-in-1 Base Module is 110V ($\pm 10\%$). If it is too low or too high, it will affect the work of the machine.
3. When you install the battery, you must not reverse the electrode or you will damage the machine.



Caution: To reduce the risk of electrical shock, do not remove the cover (or back). No user serviceable parts inside: refer servicing to qualified personnel.

Warning: To reduce the risk of fire or electrical shock, do not expose this appliance to rain or moisture.



This symbol, wherever it appears, alerts you to the presence of uninsulated dangerous voltage inside the enclosure voltage that may be sufficient to constitute a risk of shock.



This symbol, wherever it appears, alerts you to important operating and maintenance instructions in the accompanying literature. Read the manual.

Better Music Builder is a leader in the Audio and Karaoke equipment industry. We are committed to offering you the high quality audio product.

We may update our manual, so we highly recommend you to download the free update from our website www.BetterMusicBuilder.com.



Passionate about Music
www.BetterMusicBuilder.com

