



Unlike any others ... that's cost & value for you

## Professional UHF Wireless Microphone System

# VM-62U

### Operating Instructions



Frequency Selectable

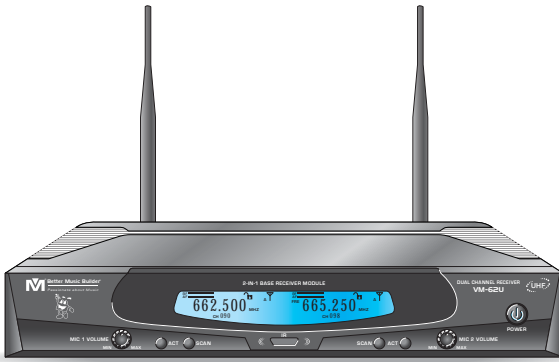

2-in-1 Base Module \*\*\*1 Receive Module with 2 Wireless Microphones System

Thank you for purchasing this unit. To make full and effective use of this unit, please read this Owner's Manual carefully before operating it. Please retain this manual for future reference.

*Passionate about Music*  
[www.BetterMusicBuilder.com](http://www.BetterMusicBuilder.com)

# CONTENTS



**INTRODUCTION..... 1**



**SYSTEM FEATURES..... 1**



**PACKAGE ACCESSORIES..... 2**



**2-in-1 BASE MODULE..... 3**

- Controls and Functions..... 3~4
- Hardware Setup..... 5~6



**HAND-HELD MICROPHONE..... 7**

- Controls and Functions..... 7~8



**OPERATION..... 9**

- How to Select Frequencies for the Receiver..... 9~10
- How to Adjust Squelch..... 11
- How to Lock/unlock the Receiver..... 11
- How to Lock/unlock the Microphone..... 11
- How to Insert/change Batteries of Microphone..... 12
- How to Adjust Radio Frequency of Microphone..... 13
- How to Turn On/Off Microphone..... 13
- How to Interchange Microphone Head..... 13



**TECHNICAL SPECIFICATION..... 14**



**BODY-PACK MICROPHONE (Optional)..... 15~16**



**TROUBLESHOOTING..... 17~18**



**APPENDIX..... 19~20**



**WARRANTY..... 21**



## INTRODUCTION

Better Music Builder is proud to introduce the newest member in our UHF wireless microphone systems: the VM-62U. It features a lighter design that includes two hand-held microphones with built-in LCD panels, Wireless Infrared Auto Sync System, and ultra long battery life.

Created for novices and professionals alike, VM-62U Wireless Microphone improves your performance and simplifies your setup. Innovations such as the Wireless Infrared Auto Sync System make setting up frequencies quick and simple. Using the technology, the microphone automatically sets the same frequency as the base module by syncing to create a complete interference free and crystal clear microphone system. It features Clear Voice, delivering crystal clearer sound quality that pro audio engineers trust. Gone are unpleasant artifact noises wireless microphones are known to emit. What you get is a cleaner, clearer sound at all audio levels.

The VM-62U Wireless Microphone is arguably the smartest microphone in the market right now. The base module has a built-in automatic frequency search capability that picks up the strongest signal in your current environment, saving you time scrolling through channels hoping for the best signal.

With years of experience designing wireless microphone system, we at Better Music Builder understand the problem with short battery life. Through intensive research we have developed a better power management system to help extend our wireless microphone battery life.

It is simply the best solution for home and professional karaoke performance.



## SYSTEM FEATURES

1. Equipped with the latest wireless technology and UHF dual-channel in a 2-in-1 Base Module to pick up weak signals and prevent signal interference.
2. Clear LCD screen displaying Frequency, Channel, Audio Frequency, Radio Frequency, Lock Setting, and Antenna Status.
3. Wireless Infrared Auto Sync System makes syncing a breeze.
4. Clear Voice delivering crystal clearer sound just like a wired microphone.
5. 100 selectable channels!
6. Ability to lock current settings.
7. Light weight mounting design for portability.
8. Adjustable antennas for better signal receiving.
9. AA battery usage for easy handling.



## PACKAGE ACCESSORIES

The package comes with one 2-in-1 Base Module [Receiver], two handheld microphones, two receiver antennas, one DC adaptor, one unbalance audio cable, and four AA batteries.

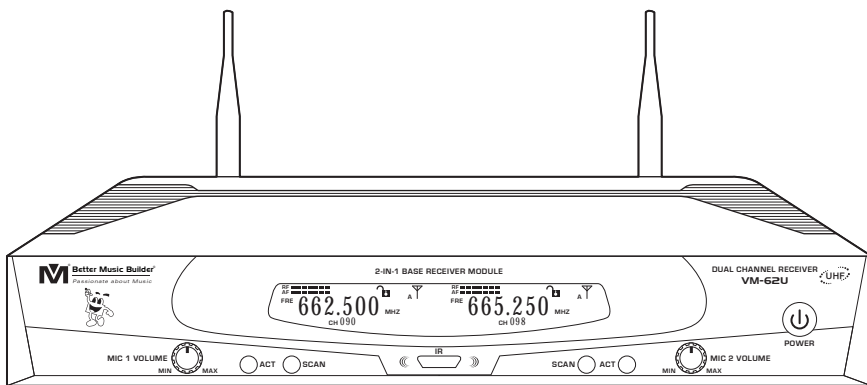

2-IN-1 BASE MODULE [RECEIVER]: 1 SET

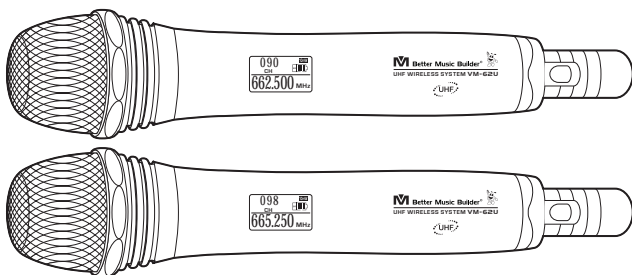

HANDHELD MICROPHONE: SET of 2

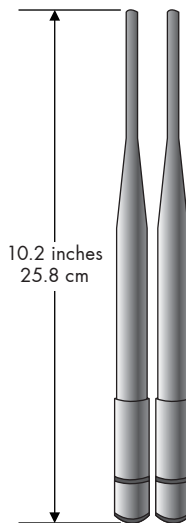

RECEIVER ANTENNA: 2 UNITS

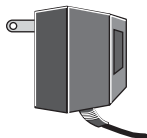

DC POWER ADAPTOR: 1 UNIT

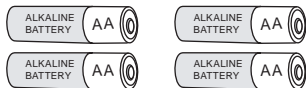

AA (1.5V) BATTERY: 4 UNITS

**NOTE** DC-POWER USAGE: This wireless microphone system is designed specifically for the North American market, which uses 120V for DC power. For usage in Asia or Europe, please change it to 220V by an adaptor with DC 14V output 500mA.

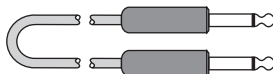

AUDIO CABLE (FOR MIXED OUTPUT): 1 UNIT



For better quality connections, a XLR to XLR cable is highly recommended.



## 2-in-1 BASE MODULE [RECEIVER]

### CONTROLS AND FUNCTIONS

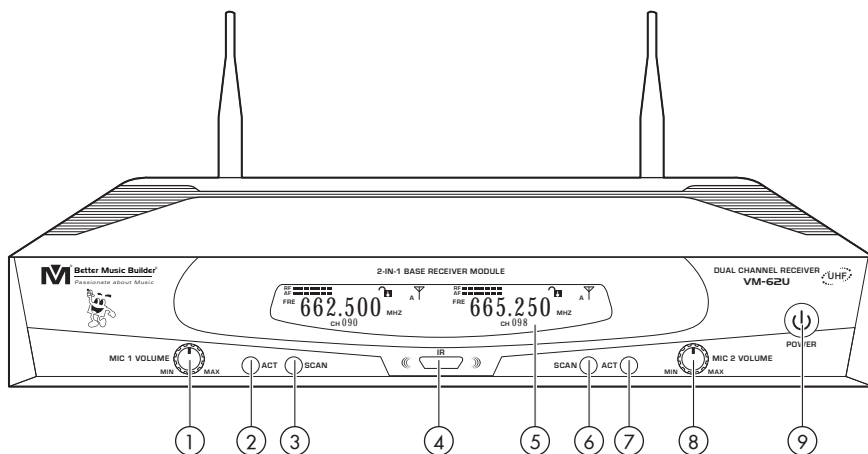

#### FRONT PANEL:

1. **MIC 1 VOLUME CONTROL:** Controls Microphone 1 volume.
2. **MIC 1 ACT BUTTON:** Automatically matches the microphone's frequency to the receiver's frequency. Holding the button for three seconds to manually select the receiver's frequency.
3. **MIC 1 SCAN BUTTON:** Automatically searches and sets the best frequency for the receiver. Holding the button for three seconds to lock/unlock settings.
4. **IR PORT:** Infrared port for the Wireless Infrared Auto Sync System. Pointing the handheld microphone's infrared port at the receiver's infrared port to allow communication.
5. **LCD SCREEN:** Displays system status.
6. **MIC 2 SCAN BUTTON:** Automatically searches and sets the best frequency for the receiver. Holding the button for three seconds to lock/unlock settings.
7. **MIC 2 ACT BUTTON:** Automatically matches the microphone's frequency to the receiver's frequency. Holding the button for three seconds to manually select the receiver's frequency.
8. **MIC 2 VOLUME CONTROL:** Controls Microphone 2 volume.
9. **POWER BUTTON:** Turns the system on/off.

## LCD PANEL:

After turning on the "POWER" button, LCD screen will display the following:

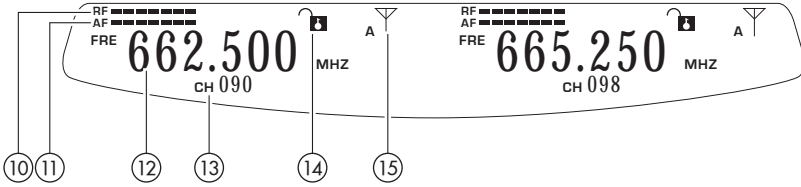

10. MIC 1 Radio Frequency: Strength indicator of radio signal.
11. MIC 1 Audio Frequency: Strength indicator of incoming audio signal.
12. MIC 1 Frequency: Displays the current frequency.
13. MIC 1 Channel: Displays the current channel.
14. MIC 1 Lock/Unlock: Shows whether current settings are locked.
15. Antenna A/B: Displays the antenna in use. When one antenna experiences noise or interference, the other antenna takes over.

## REAR PANEL:

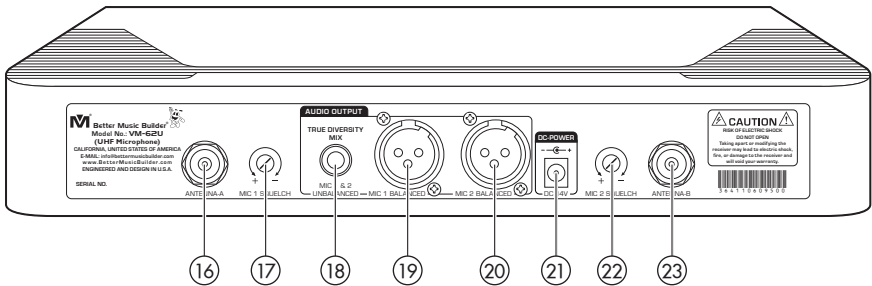

16. ANTENNA-A: Connect the antennas to the BNC socket.
17. MIC 1 SQUELCH CONTROL: Distance coverage adjustment.
18. MIXED OUTPUT: unbalanced 1/4" audio output for MIC 1 & MIC 2.
19. MIC 1 BALANCED OUTPUT: balanced XLR audio output.
20. MIC 2 BALANCED OUTPUT: balanced XLR audio output.
21. POWER SUPPLY: Removable adapter with DC14~22V 500mA.
22. MIC 2 SQUELCH CONTROL: Distance coverage adjustment.
23. ANTENNA-B: Connect the antennas to the BNC socket.



# HARDWARE SETUP

## HOW TO CONNECT AUDIO OUTPUT:

There are three rear outputs as shown in the below diagram:

**MIXED OUTPUT** is unbalanced audio output for MIC 1 & MIC 2 using 1/4" connection. When using this output, MIC 1 and MIC 2 have to share a signal. To produce different effects on each microphone, MIC 1 and MIC 2 need their own signals which can be done by using XLR connections.

**MIC 1 BALANCED OUTPUT** is balanced audio output for MIC 1 using XLR connection. When using this output, you can change MIC 1 effects without affecting MIC 2 effects.

**MIC 2 BALANCED OUTPUT** is balanced audio output for MIC 2 using XLR connection. When using this output, you can change MIC 2 effects without affecting MIC 1 effects.



We highly recommend using balanced XLR connections if the distance between the microphone receiver and the mixer is more than 10 feet. The grounding of the balanced XLR connection delivers better quality signal by reducing noise.

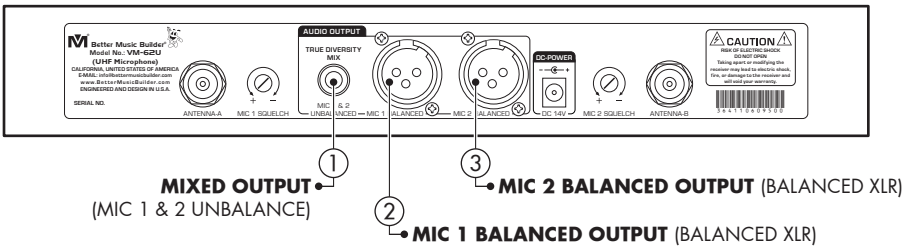

## UHF WIRELESS SYSTEM DIAGRAM:

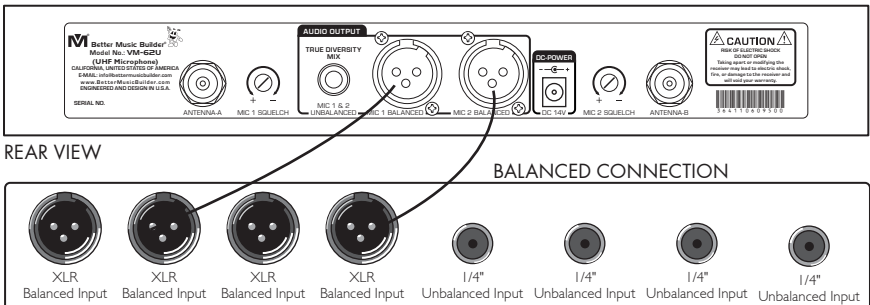

AUDIO MIXER AMPLIFIER OR A KARAOKE UNIT INPUT TERMINAL

## HOW TO CONNECT DC-POWER:

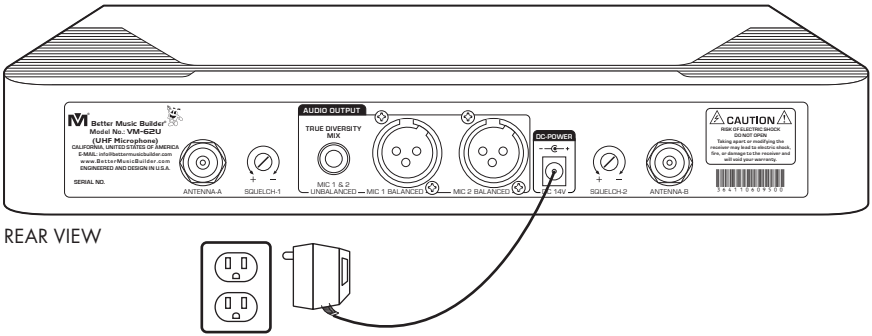

For North America Market, use 120V, DC 14~22V 500mA adaptor. For market outside North America, use 220V~ 240V DC adaptor with a maximum battery capacity of 500mA.

**NOTE** Please make sure to use the right DC adaptor. Otherwise, it may damage the 2-in-1 Base Module and the charger because their maximum battery capacity is different. The product warranty will be voided if there is damage caused by using the wrong DC adaptor.

## OPTIONAL 19" RACK MOUNT KIT:

To put the system onto a mount-kit, please follow the diagram below. Our special design feature allow it to be mounted on a DJ rack.

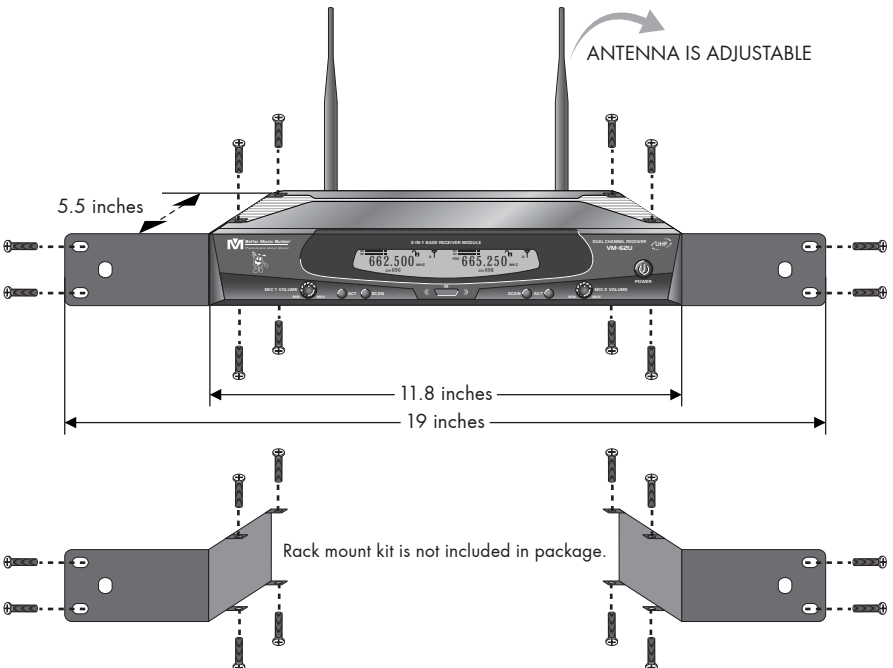





# HANDHELD MICROPHONE

## CONTROLS AND FUNCTIONS

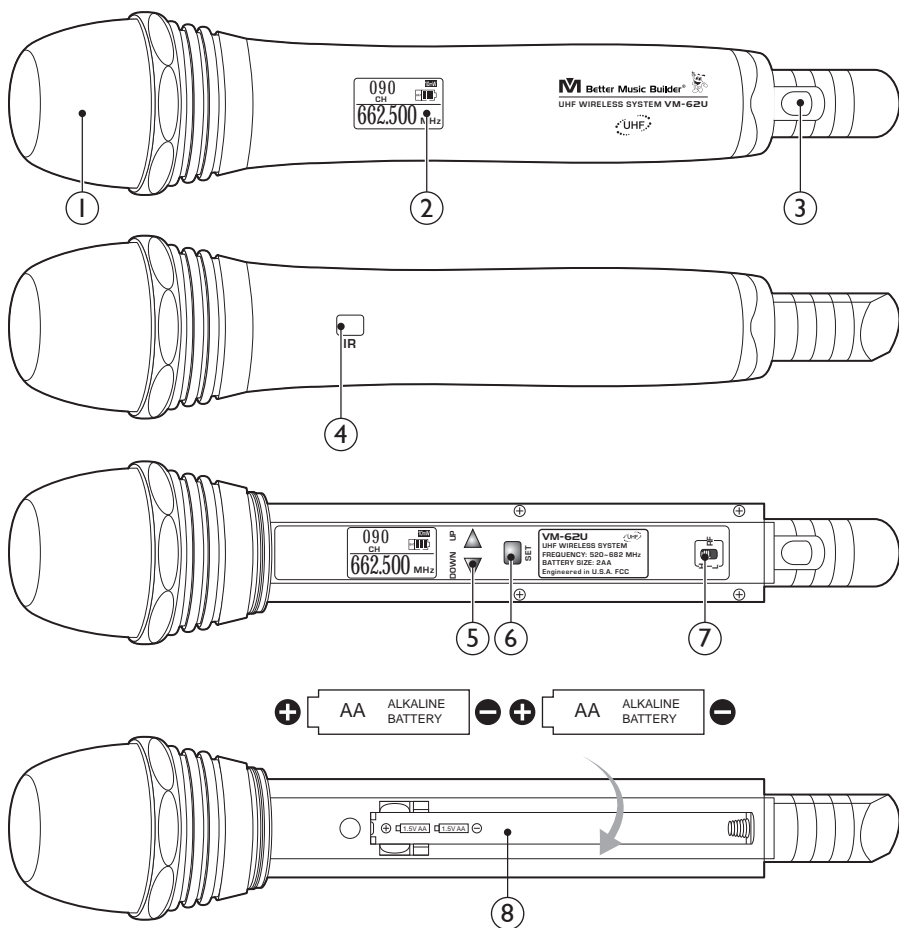

1. INTERCHANGEABLE MICROPHONE HEAD
2. LCD DIGITAL DISPLAY
3. POWER ON/OFF SWITCH BUTTON
4. IR PORT: Infrared port for the Wireless Infrared Auto Sync Technology. Point the microphone's infrared port at the receiver's infrared port to allow communication.
5. FREQUENCY SELECTION BUTTON: Press UP/DOWN button to select frequency.
6. SET BUTTON: Press SET button to confirm frequency.
7. TRANSMISSION POWER LEVEL CONTROLLER
8. BATTERY SLOTS: Insert 2x1.5V AA battery or 2x1.2V rechargeable battery.

## LCD PANEL:

After turning on the "POWER", the LCD screen will light up as below:

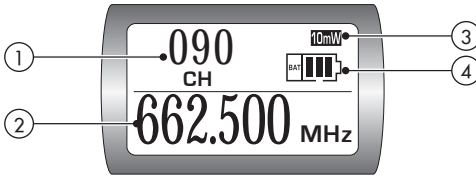

1. CHANNEL: Current value depends on your setting.
2. FREQUENCY: Current value depends on your setting.
3. RADIO FREQUENCY SIGNAL: Switch to High (10mW) to use a stronger signal and Low (5mW) to use a weaker signal.
4. BATTERY STATUS: Indicates battery life.

## BATTERY STATUS:

### Full Battery

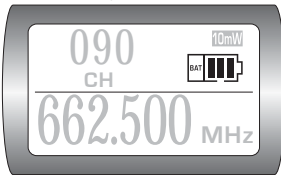

Indicates full battery on the microphone. The engineering team of Better Music Builder uses the latest technology to indicate the battery status, so you can see the battery strength.

### Low Battery

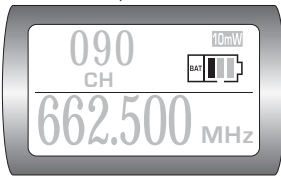

Indicates low battery on the microphone. When the microphone LCD screen is blinking or fading, its time to replace the batteries.

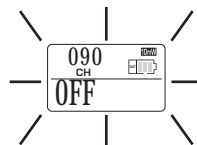

LCD screen will blink constantly when battery is extremely low and about to die.

**NOTE** ➤ If the microphone cannot be turned on, please check the battery. It may be very low. Typical new full battery life is 4~6 hours with our system, otherwise, the batteries might be defective or near expiration date.

Batteries are not covered under our product warranty.



# OPERATION

## HOW TO SELECT FREQUENCIES FOR THE RECEIVER

The 2-in-1 Base Module comes with two handheld microphones and the microphones are preset with 100 frequency channels. The frequency can be selected either automatically or manually.

### 1. AUTOMATIC FREQUENCY SELECT

**STEP 1:** Press and release the SCAN button on the receiver. It will automatically search and set the strongest frequency for the receiver.

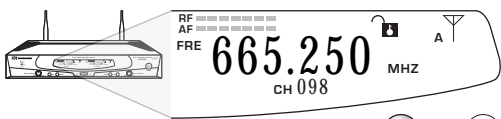

**NOTE** If the SCAN button is pressed and held for more than three seconds, the frequency will be locked

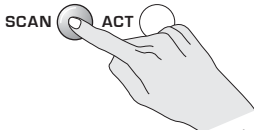

**STEP 2:** Once the frequency has been set on the receiver, point the microphone infrared port (IR) directly at the receiver infrared port (IR).

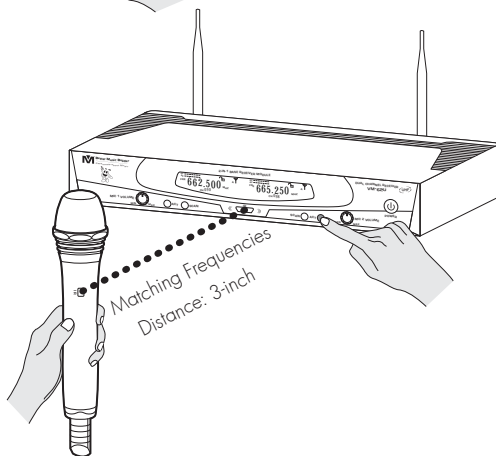

**STEP 3:** Press and release the ACT button on the receiver. It will automatically set the microphone frequency the same as the receiver frequency.

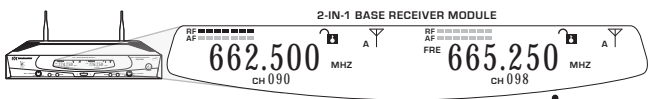

MICROPHONE AND RECEIVER FREQUENCY MATCHED

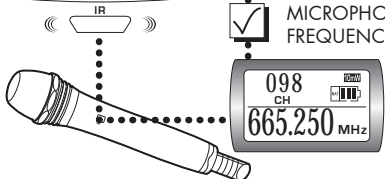

## 2. MANUAL FREQUENCY SELECT

**STEP 1:** Press and hold the ACT button on the receiver for three seconds until the frequency starts flashing, and then release the button.

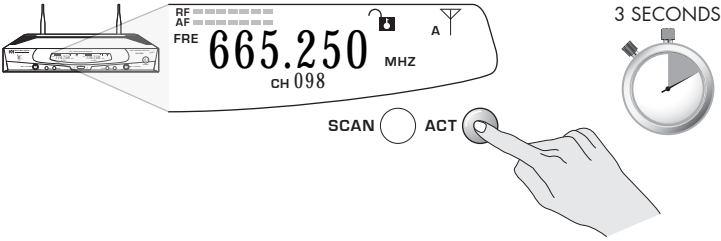

**STEP 2:** While it is flashing, press the ACT or SCAN button on the receiver to choose the desired frequency. After choosing the desired frequency, wait until it stops flashing.

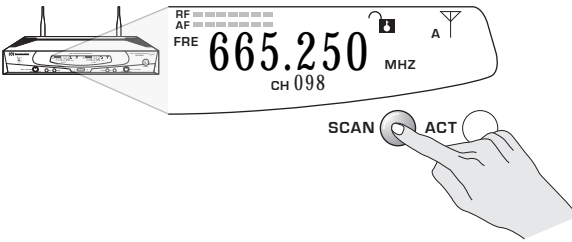

**STEP 3:** Press the UP or DOWN button on the microphone to match the receiver frequency and then press the SET button on the microphone to confirm. When the microphone frequency matches the receiver frequency, the receiver's RF bars will show.

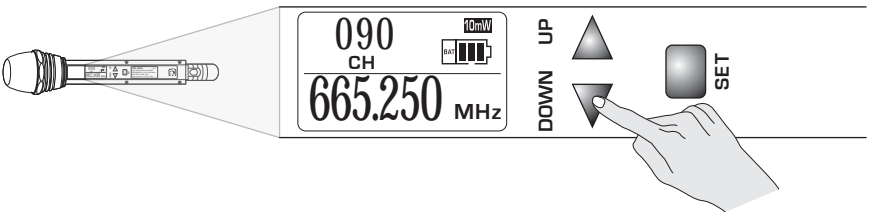

**NOTE** ➤ Please make sure that the other hand-held microphone is turned off when adjusting the frequency on one microphone.

Each unit is fully tested and qualified by the manufacturer. However, due to the nature of wireless connection, interference may occur because of local environments and/or radio signals emitted by other wireless devices within the household.

If MIC 1 or MIC 2 is actively picking up RF and/or AF signal when the handheld microphone is turned off, this is an indication that the frequency is being used by some other active device within a 200 feet radius. Therefore, selecting a different frequency is highly recommended.

## HOW TO ADJUST SQUELCH

The SQUELCH knob on the back of the receiver adjusts the distance range between the microphone and the receiver. Use a plastic screwdriver to make the squelch adjustment at the button. A higher level of squelch allows the usage of microphone further away from the receiver. However, the drawback of using a higher level of squelch is the increased chance of interference.

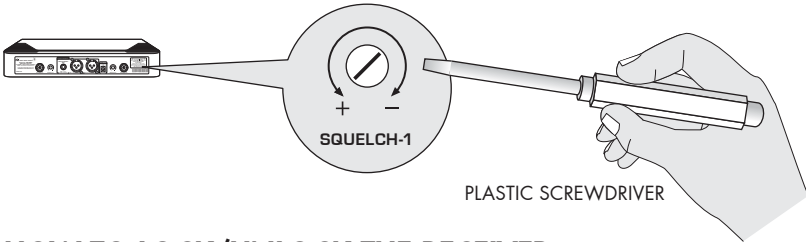

## HOW TO LOCK/UNLOCK THE RECEIVER

Press and hold the SCAN button on the receiver for more than three seconds to lock/unlock the frequency on the receiver.

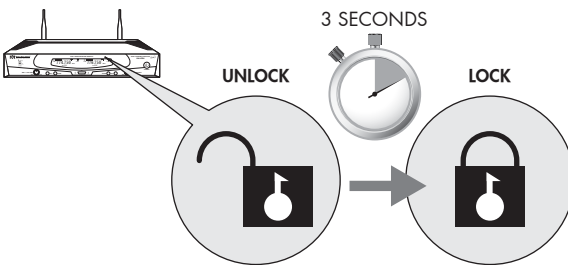

## HOW TO LOCK/UNLOCK THE MICROPHONE

**STEP 1:** Press and release the SET button on the microphone to see "LOC ON/LOC OFF" on the LCD screen.

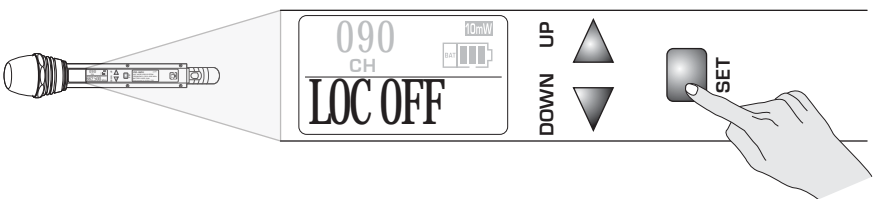

**STEP 2:** Press the UP/DOWN button to either lock or unlock the frequency/channel of the microphone.

**STEP 3:** Press the SET button to confirm. Press the SET button again to return to the main menu.

# HOW TO INSERT/CHANGE BATTERIES OF MICROPHONE

**STEP 1:** Twist open battery cover.

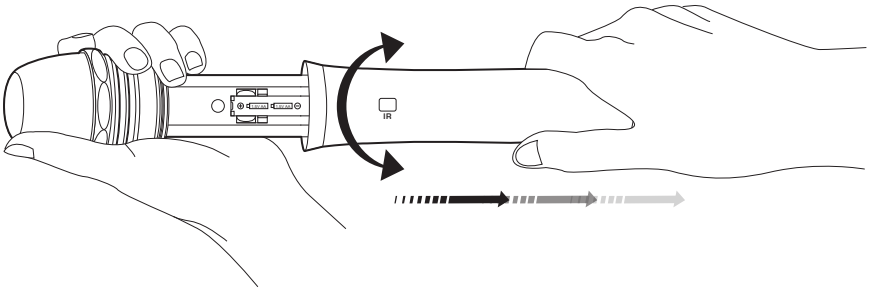

**STEP 2:** Use one hand to hold onto the top of the Microphone, and the other hand to slide 2x1.5V AA batteries into battery slot. Be careful not to drop Microphone while inserting batteries.

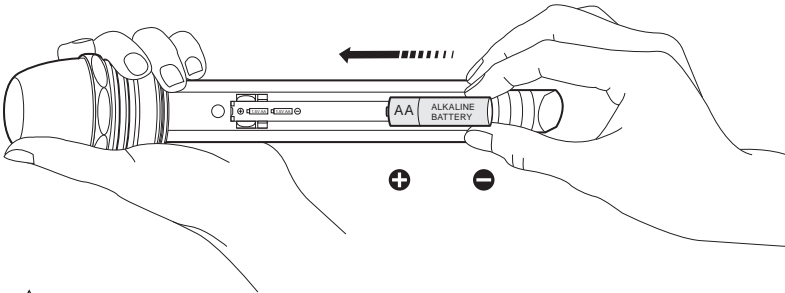

 Make sure to follow the polarity of the battery according to the battery slots.

**Good**



**No Good**



**STEP 3:** Twist back battery cover.

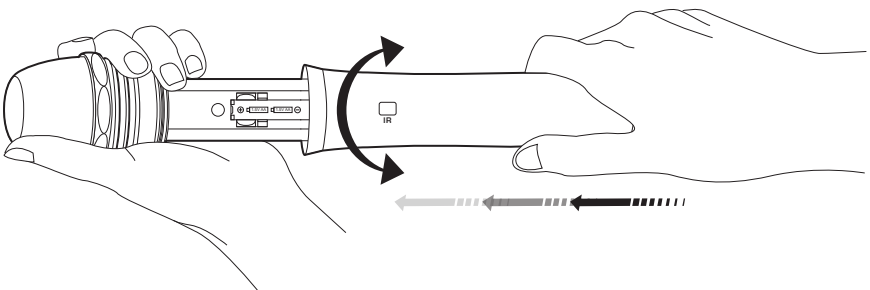

## HOW TO ADJUST RADIO FREQUENCY OF MICROPHONE

Adjust the signal of the radio frequency using the RF switch on the handheld microphone. Switch to High (10mW) to use a stronger signal and Low (5mW) to use a weaker signal. However, the drawback of using a stronger signal is the increased chance of interference.

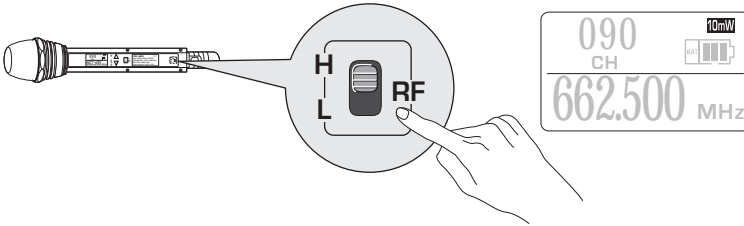

## HOW TO TURN ON/OFF MICROPHONE

**TURN ON:** Push the power switch up to turn microphone's power ON. Microphone's LED screen will displays Frequency, Channel, Radio Frequency and Battery Status.

**TURN OFF:** Push the power switch down to turn microphone's power OFF. Microphone's LED screen will be off.

After turning on the microphone's power on, there might be a need to adjust the frequency to match the receiver's frequency.

**NOTE** ▶ If the microphone cannot be turn on, please check the battery. It may be very low. Typical new full battery life is 4~6 hours with our system, otherwise, the batteries might be defective or near expiration date.

## HOW TO INTERCHANGE MICROPHONE HEAD

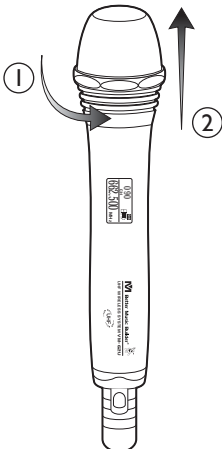

INTERCHANGEABLE  
MICROPHONE HEAD

**NOTE** ▶

Replacement parts (such as the microphone head as shown on the left) can be purchased from any of our authorized dealers.



## TECHNICAL SPECIFICATION

### A. TECHNICAL FEATURE OF THE 2-IN-1 BASE MODULE:

1. Channel: 100 Channels
2. Frequency Range: UHF 520~682 MHz
3. Signal to Noise Ratio: > 90dB
4. Total Harmonic Distortion: < 0.05%
5. Band Width: < 200kHz
6. Frequency Response: 35Hz~20kHz +/-3dB
7. Dynamic Range: > 100dB
8. Valid Distance: 0.50m
9. Audio Output Level: Unbalanced Out: 0~+/-400mV  
Balanced Out: 0~+/-200mV
10. Power Supply: DC 14V~22V with 500mA~1000mA, AC 120V (For 220V, you may need to change to a 220V~240V DC adaptor)
11. Consume Power: 5 Watts
12. Receiver Dimensions (WxHxD): 11.8 x 1.9 x 7.1 (inches) / 30 x 4.8 x 18 (cm)
13. Package Dimensions (WxHxD): 16.9 x 13.8 x 3 (inches) / 43 x 35 x 7.5 (cm)
14. Shipping Weight: 5.6 lbs / 2.5 kg

### B. TECHNICAL FEATURE OF THE MICROPHONE:

1. Transmitter Power: 5mW and 10mW
2. Oscillation Mode: PLL
3. Image Controlment: >50dB
4. Adjust Frequency Deviation: <75kHz
5. Channel Switch Mode: Coding Switch
6. Power Supply: DC 2.4V~4.8V
7. Battery Voltage: 2 x AA 1.5V Alkaline Battery
8. Continuous Using: 8 Hours (GP) 2 x AA 1.5V Battery
9. Microphone Dimensions (WxH): 10.4 x 2.2 (inches) / 26.5 x 5.5 (cm)

### C. THIS SYSTEM INCLUDES THE FOLLOW:

- 2-in-1 Base Module: 1 Set
- Handheld Microphone: 2 Sets
- Antenna: 2 Units
- AA 1.5V Battery: 4 Units
- DC-Power Adaptor: 1 Unit
- Audio Cable: 1 Unit
- Instructional Manual: 1 Unit





# BODY-PACK MICROPHONE SYSTEM SPECIFICATION (Optional)

## NAMES & FUNCTION:

### Body-Pack Microphone System (including Lavalier Mic. and Headset Mic.)

#### Outside Picture

1. Antenna
2. 4-pin Microphone Input Jack
3. LCD Digital Display
4. IR Port: Receives infrared beam to synchronize frequencies. IR when using multiple systems, only one microphone port should be exposed at a time
5. Battery Cover
6. Tie-Clip
7. Microphone Extension Jack

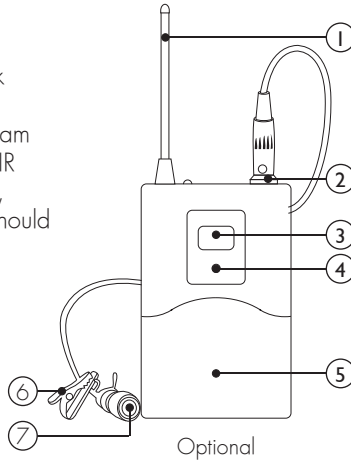

#### Side-face Picture

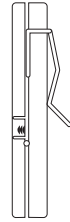

Optional

#### Inside Picture

1. Power/Mute indicator
  - Green: Ready
  - Amber: Mute Open
  - Flashing Red: IR is transmission in process
  - Glowing Red: Low battery power
  - Pulsing Red: Battery dead (microphone cannot be turned off until batteries are changed)
2. Power ON/OFF/mute switch Button: Press and hold the microphone for 3 seconds to turn power ON/OFF. Press and release to mute or un-mute the microphone.
3. Adjustment switch
4. Battery Slot

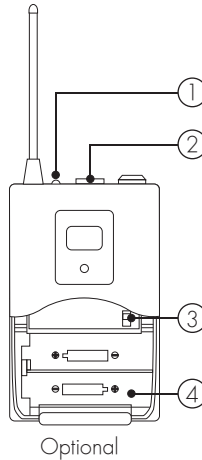

Optional

#### Lavalier Mic.

(Accessories)

1/4" to mini 3-pin lavalier cable

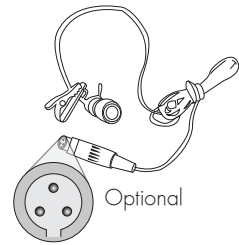

Optional

#### Headset Mic.

(Accessories)

1/4" to mini 3-pin lavalier cable



Optional

#### Apical Panel

1. Antenna Jack
2. Power/Mute indicator
3. Power Switch
4. Microphone Input Jack

Body-pack Microphone Top View

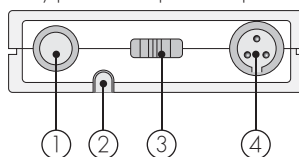

## HOW TO INSERT BODY-PACK MICROPHONE BATTERIES

**STEP 1:** Open battery cover.

**STEP 2:** Insert 2 AA alkaline batteries. 2 alkaline batteries are expected to use for about 8 hours.

Make sure that you insert batteries correctly, as shown in picture. When the microphone body-pack light glows red, the batteries should be changed immediately.

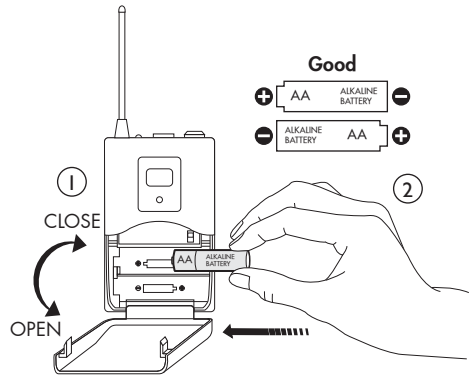

## HOW TO WEAR BODY-PACK MICROPHONE

The microphone can be buckled to the belt or the guitar band. For best result, the microphone should be pushed down until the belt is close to the base of microphone.

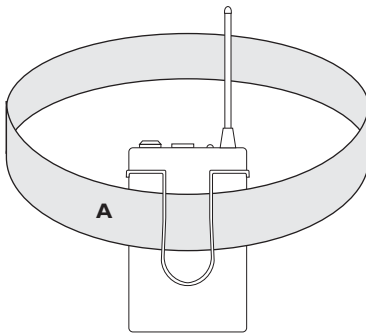

MICROPHONE BODY-PACK  
REAR VIEW

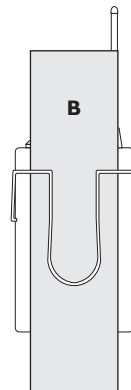

MICROPHONE BODY-PACK  
REAR VIEW

## ADJUSTMENT GAIN

Three gain settings are available. Choose the appropriate setting for your instrument.

- MIC: for the microphone adjustment
- 0: Guitar with passive pickups
- -10: Guitar with active pickups

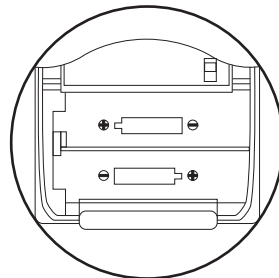



# TROUBLESHOOTING

**! CAUTION:** Before troubleshooting any symptoms make sure the equipments are in the "OFF" position.

## 1. SYMPTOM: NO SOUND COMING FROM MICROPHONE

**A. CAUSE:** There is no indication of signal.

- a. Turn microphone to "OFF" position. Check if batteries are inserted correctly.
- b. If batteries are inserted correctly, but there is no power, insert new batteries
- c. Make sure the microphone and receiver are in the same channel
- d. The volume may be turned to a low level.

**B. CAUSE:** The receiver is unpowered.

Make sure the power adapter is connected properly and there is power coming from the power outlet.

**C. CAUSE:** There is no indication of AF signal.

Turn off the receiver and make sure it is properly connected to the mixer or amplifier. If it is, slowly turn the volume higher.

**D. CAUSE:** There is no indication of RF signal.

If there is no indication of RF signal there may be interference between the receiver and the microphone. Change the channel between the microphone and receiver otherwise; Adjust the antenna of the receiver and/or move away objects between receiver and the microphone .

**2. SYMPTOM: ONE OR MORE OF THE MICROPHONE IS NOT WORKING, CHECK THE SOLUTIONS FOR CAUSES A~D ABOVE.**

## 3. SYMPTOM: RANDOM NOISE COMING OUT FROM MICROPHONE

**CAUSE:** There are interference within your area.

1. Change the channel between the microphone and receiver.
2. Stand further away from your speaker.

**4. SYMPTOM: THE MICROPHONE SUDDENLY HAS NO SOUND AND THE RECEIVER LCD LIGHT IS OFF.**

Make sure the AC power adapter is securely plugged into the electrical outlet and into the DC input connector on the rear panel of the receiver. Make sure the AC electrical outlet works and is supplying the proper voltage.

**5. SYMPTOM: THE MICROPHONE SUDDENLY HAS NO SOUND BUT THE RECEIVER SHOWS RF SIGNAL.**

**CAUSE:** The microphone out lead is damaged or disconnected.

To fix it, open the microphone head cover to check on the microphone out lead and re-connect the wire by welding. If it does not work, replace the microphone out lead.

**6. SYMPTOM: THE MICROPHONE DISTORTION LEVEL IS INCREASING GRADUALLY.**

**CAUSE:** The microphone batteries are running out.

Replace the microphone batteries.

**7. SYMPTOM: POOR SIGNAL**

**CAUSE:** When the 2-in-1 Base Module and microphone are placed in different rooms made of concrete wall. This would cause poor signal.

Your audio equipment is close to the police, fire or radio stations. In this case, a different frequency channel **MUST** be selected. Both the microphone and the 2-in-1 Base Module must change to a matching frequency.

**8. SYMPTOM: THE FREQUENCY OF THE MICROPHONE IS DIFFERENT FROM THE 2-in-1 Base Module.**

The microphone's frequency must match with 2-in-1 Base Module's frequency.



## APPENDIX

### VM-62U FCC FREQUENCY: 658.000~682.750 MHz

#### UHF Frequencies Available for Use for Home Electronics in North America

The RF radio frequencies used in the transmission of wireless information are closely regulated in most countries including North America. A lot of countries strictly enforce their regulations stating which RF frequencies are available for use for certain device, so it can help limit the amount of radio frequency interference in all wireless communications.

Please refer to the following table for MIC 1 and MIC 2 with available RF frequencies. If the RF frequencies indicated in the following table are in conflicts with the local wireless information law in your country, please switch to a different product model or contact our technicians for advice.

#### FCC Information to User for Reference

This equipment is designed in compliance with the limits for a Class A digital device pursuant to part 15 of the FCC Rules from the United States of America. These limits are designed to provide protection against harmful interference when the equipment is operated in public environment. This equipment generates, uses, and can radiates radio frequency energy and, if not installed and used in accordance with the instruction manual, may cause harmful interference to radio communications. Operation of this equipment in a residential area may cause harmful interference, so the user will have to correct the interference at his/her own expense.

# MIC 1 & MIC 2 FREQUENCY: 658.000~682.750 MHz

CH	FREQUENCY	CH	FREQUENCY	CH	FREQUENCY	CH	FREQUENCY
1	658.000	26	664.250	51	670.500	76	676.750
2	658.250	27	664.500	52	670.750	77	677.000
3	658.500	28	664.750	53	671.000	78	677.250
4	658.750	29	665.000	54	671.250	79	677.500
5	659.000	30	665.250	55	671.500	80	677.750
6	659.250	31	665.500	56	671.750	81	678.000
7	659.500	32	665.750	57	672.000	82	678.250
8	659.750	33	666.000	58	672.250	83	678.500
9	660.000	34	666.250	59	672.500	84	678.750
10	660.250	35	666.500	60	672.750	85	679.000
11	660.500	36	666.750	61	673.000	86	679.250
12	660.750	37	667.000	62	673.250	87	679.500
13	661.000	38	667.250	63	673.500	88	679.750
14	661.250	39	667.500	64	673.750	89	680.000
15	661.500	40	667.750	65	674.000	90	680.250
16	661.750	41	668.000	66	674.250	91	680.500
17	662.000	42	668.250	67	674.500	92	680.750
18	662.250	43	668.500	68	674.750	93	681.000
19	662.500	44	668.750	69	675.000	94	681.250
20	662.750	45	669.000	70	675.250	95	681.500
21	663.000	46	669.250	71	675.500	96	681.750
22	663.250	47	669.500	72	675.750	97	682.000
23	663.500	48	669.750	73	676.000	98	682.250
24	663.750	49	670.000	74	676.250	99	682.500
25	664.000	50	670.250	75	676.500	100	682.750



## WARRANTY

### One-Year Limited Warranty for Home Use Equipment

Our one-year warranty applies to speakers, amplifiers, mixers and microphones for home use only. It covers both parts and labors. The warranty becomes effective on the date of your purchase.

Our warranty only covers defects due to product defectiveness with free of defects in materials or workmanship. However, our warranty does not cover defects due to normal wears, damage in transit, improper use, abuse or failure to follow the proper instructions for maintenance. This warranty is void in the event of unauthorized repairs, alternations, modifications and removing of the product label.

Please also note that our warranty does not cover any shipping cost for the return of defective products to us for inspection, repair and maintenance. Our warranty for Better Music Builder products can only be executed in North America.

**NOTE** ► Our warranty does not cover the battery for wireless microphone products.

### 90-Day Limited Warranty for Public and Commercial Use Equipment

Our 90-day warranty applies to speakers, amplifiers, mixers and microphones for both public and commercial use such as restaurant, coffee shop, KTV nightclub, church and school, etc. It covers both parts and labors. The warranty becomes effective on the date of your purchase.

### To Register Your Warranty

Please submit the warranty card that comes with your unit; it is also download on our website . However, we need the invoice for your purchase in order to process this warranty. You may also register your warranty online.

Please visit our website at [www.BetterMusicBuilder.com](http://www.BetterMusicBuilder.com).

## PRECAUTION

1. If using more than one microphone system, please select the operating frequency or signal channel carefully so as to avoid disturbing.
2. The input power voltage of the 2-in-1 Base Module is 110V/120V ( $\pm 10\%$ ). If it is too low or too high, it will affect the work of the machine.
3. When installing batteries, reversing the electrode will damage the machine.



**Caution:** To reduce the risk of electrical shock, do not remove the cover (or back). No user serviceable parts inside: refer servicing to qualified personnel.

**Warning:** To reduce the risk of fire or electrical shock, do not expose this appliance to rain or moisture.



This symbol, wherever it appears, alerts you to the presence of uninsulated dangerous voltage inside the enclosure voltage that may be sufficient to constitute a risk of shock.



This symbol, wherever it appears, alerts you to important operating and maintenance instructions in the accompanying literature. Read the manual.







Better Music Builder is a leader in the Audio and Karaoke equipment industry. We are committed to offering you the high quality audio product.

We may update our manual, so we highly recommend you to download the free update from our website [www.BetterMusicBuilder.com](http://www.BetterMusicBuilder.com).



*Passionate about Music*  
**[www.BetterMusicBuilder.com](http://www.BetterMusicBuilder.com)**



Code: 20110901

♻️ Printed on 100% Recycled Paper Comments E-mail to [sales@bettermusicbuilder.com](mailto:sales@bettermusicbuilder.com) Copyright © 2011 Better Music Builder. All rights reserved. Legal trademark.