

Professional Karaoke Speaker System

Model: CS-812

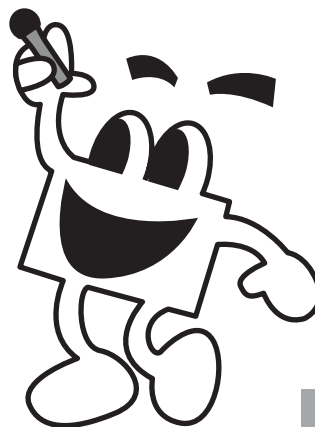

Thank you for purchasing this unit. To make full and effective use of this unit, please read this Owner's Manual carefully before operating it. After reading this manual, retain this booklet together with the Warranty Card for future use in case of maintenance or troubleshooting.



Passionate about Music

www.BetterMusicBuilder.com



CAUTION

RISK OF ELECTRIC SHOCK
DO NOT OPEN



CAUTION: TO REDUCE THE RISK OF ELECTRIC SHOCK
DO NOT REMOVE COVER (OR BACK) NO
USER-SERVICEABLE PARTS INSIDE REFER SERVICING
TO QUALIFIED PERSONNEL

CAUTIONS FOR INSTALLATION

When installing the speaker on a wall or ceiling, it should be secured firmly using rigid anchor bolts to prevent it from coming off. Also, care should be taken with regard to the resonance of the mounting brackets caused by speaker operations.

If the speaker is operated at high output levels, the floor, wall or ceiling may vibrate, which will impair the sound quality. Special care should be taken to prevent resonance and vibrations caused by the mounting angles.

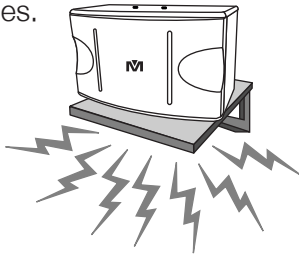

NOTE

Always be sure that the surface chosen for mounting is structurally capable of supporting the weight of the speaker. Do not mount more than one speaker into one Ceiling Mounting Bracket (optional). Also, avoid having sound absorbing material such as curtains, etc. on the wall or placing the speakers too close to the window.

INSTALLATION EXAMPLE

1. KTV/Large Hall Installation

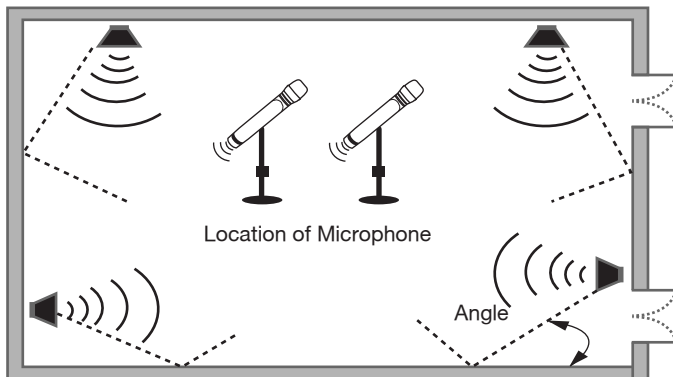

NOTE

When using several speakers at the same time, special care must be taken to ensure that the output level of the speakers would match each other in order to avoid feedback which may burn the tweeter with high frequency.

2. Mounting the Speaker to the Ceiling

Place the ceiling mount bracket (Model: SPS-706) on the top of the speaker cabinet and put two screws to fasten it. Then, put one screw to hold the speaker firmly to the ceiling. Adjust the speaker up/ down and left/right for rotation at different angles to achieve the maximum sound effect. Please refer to the above diagram for instruction.

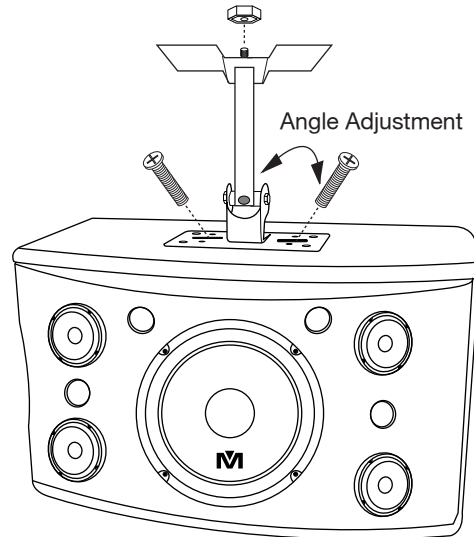

NOTE

The structure of the ceiling must be strong enough to hold at least 50 pounds. The ceiling mount bracket in the diagram is Model: SPS-706 and it is optional.

3. Mounting the Speaker to the Wall

Place the wall mount panel on the top of the speaker cabinet and put two screws to fasten it. Then, put four screws to hold the speaker firmly into the wall. Adjust the speaker up/ down and left/right for rotation at different angles to achieve the maximum sound effect. Please refer to the above diagram for instruction.

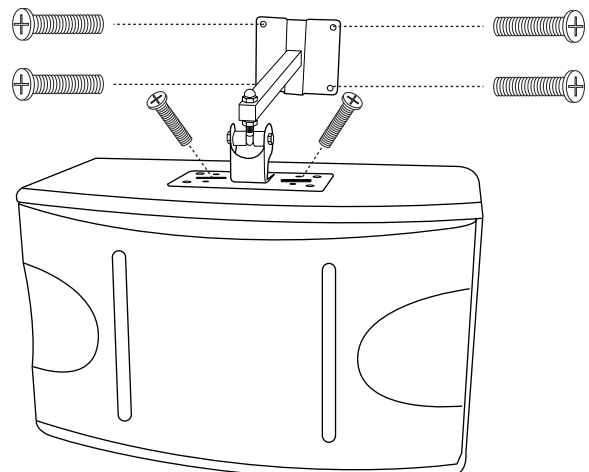

PLACING THE SPEAKERS

The speakers can be mounted on to the optional portable stand, (see figure below). Make sure that the mounting system (hardware, stand, etc.) is capable of supporting four times the weight (approximately 25 lbs per speaker) of the speakers.

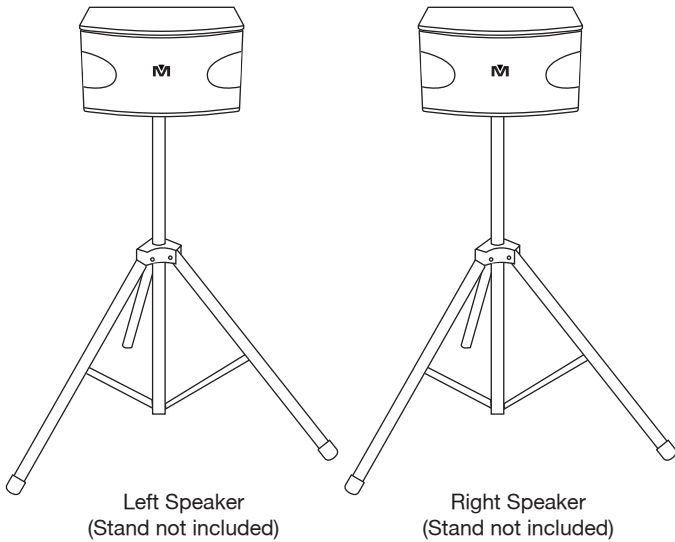

NOTE Please do not stack two-pieces of speakers onto the adjustable speaker stand.

Circuit Diagram

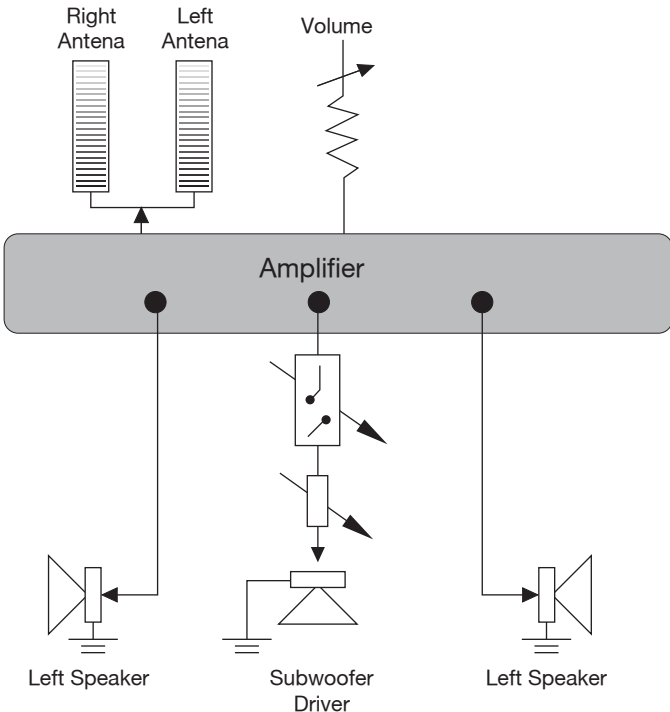

CONNECTION OF SPEAKER CABLES

There are two types of speaker input terminals which should be selected according to application. (see figures)

1. Use of banana type terminals:

Insert the banana-type terminal cable from the amplifier into the speaker terminal hole. The plus "+" side is marked red and minus "-" side is marked black.

2. Use of insert-type terminals:

Depress the insert-type terminal cable from the amplifier into the speaker terminal hole. The plus "+" side is marked red and minus "-" side is marked black.

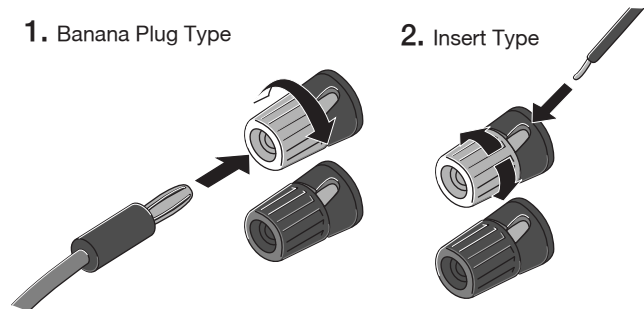

Before connecting the speaker to connection, you must make sure that the master volume and the AC power are off. Otherwise, it may burn your speaker. Then, double check the connection to match the "+" and "-" correctly.

NO WARRANTY AFTER OPENING



No opening on speaker frame or repairing the components inside the speaker. We always recommend you to hire professional to do the speaker connection and repair.



AFC 2005-0305 US Right

Engineered by **Better Music Builder** Expert Design Plus Dynamics 2007

SPECIFICATIONS

CS-812

Woofers: 12" Woofer (1 unit)
Tweeters: 4 x 3 inches (4 unit)
Normal Impedance: 8 Ω
Frequency Response: 40~20 KHz
Power Handling: 600 Watts
Sensitivity (1W/1M): 93dB
Crossover Frequency: 300 Hz
LF Low-Pass Slope: -6 dB/Oct
HF High-Pass Slope: -12 dB/Oct
Voice Coil (mm): ϕ 51
Magnet Weigh (g): 1290
Dimension (WxHxD): 32.5 x 14 x 13 (inches)
80.5 x 35.6 x 33 (cm)
Net Weight: 33 lbs / 14.97 kg (each)
Shipping Weight: 40 lbs / 18.2 kg (each)
Cabinet: Made of Piano Wood

NUTS AND SCREWS

